



Installation and Operation Instructions Comfort Flame™ Vent Free Compact Fireplace System



P/N 900567-00 Rev. N/C 09/2015



Report No. F09-168

Models

Thermostat Models: Brookhill26ZTN Brookhill26ZTP	Remote-Ready Models: Concord26ZMN Concord26ZMP
---	---

INSTALLER: Leave this manual with the appliance.
CONSUMER: Retain this manual for future reference.

This appliance may be installed in an aftermarket permanently located, manufactured (mobile) home, where not prohibited by local codes. This appliance is only for use with the type of gas indicated on the rating plate. This appliance is not convertible for use with other gases.

This is an unvented gas-fired heater. It uses air (oxygen) from the room in which it is installed. Provisions for adequate combustion and ventilation air must be provided. Refer to Air for Combustion and Ventilation section on page 6 of this manual.

⚠ WARNING: If the information in these instructions is not followed exactly, a fire or explosion may result causing property damage, personal injury or loss of life.

⚠ WARNING:
FIRE OR EXPLOSION HAZARD

Failure to follow safety warnings exactly could result in serious injury, death, or property damage.

- Do not store or use gasoline or other flammable vapors and liquids in the vicinity of this or any other appliance.
- **WHAT TO DO IF YOU SMELL GAS:**
 - Do not try to light any appliance.
 - Do not touch any electrical switch; do not use any phone in your building.
 - Leave the building immediately.
 - Immediately call your gas supplier from a neighbor's phone. Follow the gas supplier's instructions.
 - If you cannot reach your gas supplier, call the fire department.
- Installation and service must be performed by a qualified installer, service agency or the gas supplier.

Thank you for your purchase. We appreciate your business!

Please carefully read and follow all instructions in this manual. **Pay special attention to all warnings and safety information.**

Following these safety, care, and operation instructions will help ensure many years of dependable and enjoyable service from your fireplace.

Register your product online today!

To help us keep you up-to-date on product information and offers, please take a few moments to register your product online at Comfortflame.US.com

Please read and understand these instructions before installing or operating.



We recommend that our gas hearth products be installed and serviced by professionals who are certified in the U.S. by the National Fireplace Institute® (NFI) as NFI Gas Specialists.

www.nficertified.org

TABLE OF CONTENTS

Safety.....	2
Product Identification.....	4
Optional Remote Control Accessories.....	4
Local Codes	4
Requirements for the Commonwealth of Massachusetts.....	4
Product Features.....	5
Unpacking.....	5
Hood Assembly.....	5
Air for Combustion and Ventilation	6
Installation	8
Operation	16
Inspecting Burners	20
Cleaning and Maintenance	21
Wiring Diagram.....	21
Troubleshooting.....	22
Specifications.....	25
Service Hints.....	25
Technical Service	25
Replacement Parts.....	25
Parts	26
Accessories.....	32
Warranty	35

SAFETY

⚠ WARNING: Improper installation, adjustment, alteration, service or maintenance can cause injury or property damage. Refer to this manual for correct installation and operational procedures. For assistance or additional information consult a qualified installer, service agency or the gas supplier.

⚠ WARNING: This is an unvented gas-fired heater. It uses air (oxygen) from the room in which it is installed. Provisions for adequate combustion and ventilation air must be provided. Refer to Air for Combustion and Ventilation section on page 6 of this manual.

This appliance may be installed in an aftermarket, * permanently located, manufactured (mobile) home, where not prohibited by local codes.

This appliance is only for use with the type of gas indicated on the rating plate. This appliance is not convertible for use with other gases.

* **Aftermarket:** Completion of sale, not for purpose of resale, from the manufacturer

⚠ WARNING: This product contains and/or generates chemicals known to the State of California to cause cancer or birth defects or other reproductive harm.

IMPORTANT: Read this owner’s manual carefully and completely before trying to assemble, operate or service this fireplace. Improper use of this fireplace can cause serious injury or death from burns, fire, explosion, electrical shock and carbon monoxide poisoning.

⚠ DANGER: Carbon monoxide poisoning may lead to death!

Carbon Monoxide Poisoning: Early signs of carbon monoxide poisoning resemble the flu, with headaches, dizziness or nausea. If you have these signs, the fireplace may not be working properly. Get fresh air at once! Have fireplace serviced. Some people are more affected by carbon monoxide than others. These include pregnant women, people with heart or lung disease or anemia, those under the influence of alcohol and those at high altitudes.

Natural and Propane/LP Gas: Natural and propane/LP gases are odorless. An odor-making agent is added to the gas. The odor helps you detect a gas leak. However, the odor added to the gas can fade. Gas may be present even though no odor exists.

Make certain you read and understand all warnings. Keep this manual for reference. It is your guide to safe and proper operation of this fireplace.

SAFETY Continued

⚠ WARNING: Any change to this fireplace or its controls can be dangerous.

⚠ WARNING: Do not use a blower insert, heat exchanger insert or other accessory not approved for use with this fireplace.

⚠ WARNING: Do not allow fans to blow directly into the fireplace. Avoid any drafts that alter burner flame patterns. Ceiling fans can create drafts that alter burner flame patterns. Altered burner patterns can cause sooting.

Due to high temperatures, the appliance should be located out of traffic and away from furniture and draperies.

Do not place clothing or other flammable material on or near the appliance. Never place any objects on the heater.

Fireplace front and screen become very hot when running heater. Keep children and adults away from hot surfaces to avoid burns or clothing ignition. Fireplace will remain hot for a time after shutdown. Allow surfaces to cool before touching.

Carefully supervise young children when they are in the room with fireplace. When using the hand-held remote accessory (Remote-Ready Models Only), keep selector switch in the OFF position to prevent children from turning on burners with remote.

You must operate this fireplace with the fireplace screen in place. Make sure fireplace screen is closed before running fireplace.

Keep the appliance area clear and free from combustible materials, gasoline and other flammable vapors and liquids.

1. This appliance is only for use with the type of gas indicated on the rating plate. This appliance is not convertible for use with other gases.
2. Do not place propane/LP supply tank(s) inside any structure. Locate propane/LP supply tank(s) outdoors.
3. If you smell gas
 - shut off gas supply
 - do not try to light any appliance
 - do not touch any electrical switch; do not use any phone in your building
 - immediately call your gas supplier from a neighbor's phone. Follow the gas supplier's instructions
 - if you cannot reach your gas supplier, call the fire department
4. This fireplace shall not be installed in a bedroom or bathroom.
5. Do not use this fireplace as a wood-burning fireplace. Use only the logs provided with the fireplace.
6. Do not add extra logs or ornaments such as pine cones, vermiculite or rock wool. Using these added items can cause sooting. Do not add lava rock around base. Rock and debris could fall into the control area of fireplace.
7. This fireplace is designed to be smokeless. If logs ever appear to smoke, turn off fireplace and call a qualified service person. Note: During initial operation, slight smoking could occur due to log curing and fireplace burning manufacturing residues.
8. To prevent the creation of soot, follow the instructions in Cleaning and Maintenance, page 21.
9. Before using furniture polish, wax, carpet cleaner or similar products, turn fireplace off. If heated, the vapors from these products may create a white powder residue within burner box or on adjacent walls or furniture.
10. This fireplace needs fresh air ventilation to run properly. This fireplace has an Oxygen Depletion Sensing (ODS) safety shutoff system. The ODS shuts down the fireplace if not enough fresh air is available. See Air for Combustion and Ventilation, page 6. If fireplace keeps shutting off, see Troubleshooting, page 22.
11. Do not run fireplace
 - where flammable liquids or vapors are used or stored.
 - under dusty conditions.
12. Do not use this fireplace to cook food or burn paper or other objects.
13. Never place any objects in the fireplace or on logs.
14. Do not use fireplace if any part has been under water. Immediately call a qualified service technician to inspect the room fireplace and to replace any part of the control system and any gas control which has been under water.
15. Turn off and unplug fireplace and let cool before servicing. Only a qualified service person should service and repair fireplace.
16. Operating fireplace above elevations of 4,500 feet could cause pilot outage.
17. Do not operate fireplace if log is broken. Do not operate fireplace if log is chipped (dime-sized or larger).
18. To prevent performance problems, do not use propane/LP fuel tank of less than 100 lb. capacity.
19. Provide adequate clearances around air openings.
20. The screen or any other part removed for servicing must be replaced prior to operating this heater.

PRODUCT IDENTIFICATION

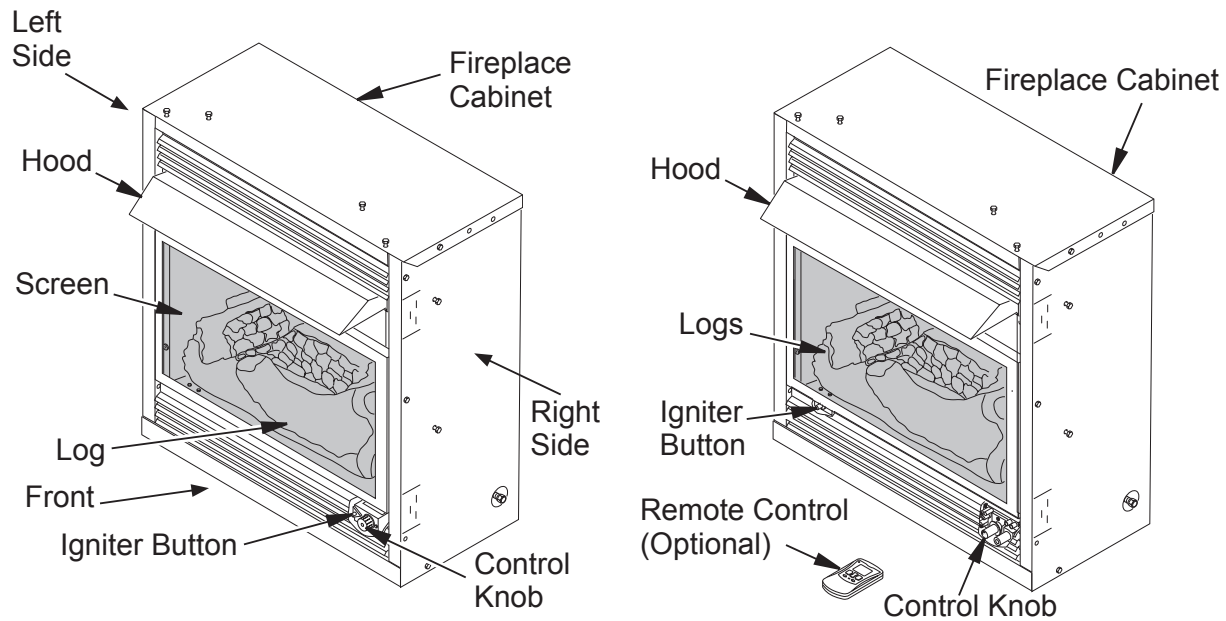

Figure 1 - Vent-Free Compact Fireplace

OPTIONAL REMOTE CONTROL ACCESSORIES

(For Remote-Ready Models Only)

There are five optional remote controls that can be purchased separately for Remote-Ready Models only:

- wall switch
- hand-held ON/OFF remote
- wall thermostat
- hand-held thermostat remote
- hand-held touch-screen thermostat remote

See Accessories, page 32.

LOCAL CODES

Install and use fireplace with care. Follow all local codes. In the absence of local codes, use the latest edition of The National Fuel Gas Code ANSI Z223.1/NFPA 54*.

*Available from:

American National Standards Institute, Inc.
25 West 43rd Street, 4th floor
New York, NY 10036

National Fire Protection Association, Inc.
1 Batterymarch Park
Quincy, MA 02169-7471

State of Massachusetts: The installation must be made by a licensed plumber or gas fitter in the Commonwealth of Massachusetts.

Sellers of unvented propane or natural gas-fired supplemental room heaters shall provide to each purchaser a copy of 527 CMR 30 upon sale of the unit.

Vent-free gas products are prohibited for bedroom and bathroom installation in the Commonwealth of Massachusetts.

COMMONWEALTH OF MASSACHUSETTS REQUIREMENTS

These appliances are approved for installation in the US state of Massachusetts if the following additional requirements are met:

- Un-vented Room Heaters shall be installed in accordance with 527 CMR 30.
- Installation and repair must be done by a plumber or gas fitter licensed in the Commonwealth of Massachusetts.
- The flexible gas line connector used shall not exceed 36 inches (92 centimeters) in length.
- The individual manual shut-off must be a T-handle type valve.
- Unvented appliances may NOT be installed in bedrooms or bathrooms.
- A working smoke detector must be installed in the area where vent-free appliances are installed.

Seller of unvented propane or natural gas-fired supplemental room heaters shall provide to each purchaser a copy of 527 CMR 30 upon sale of the unit.

PRODUCT FEATURES

SAFETY PILOT

This fireplace has a pilot with an Oxygen Depletion Sensing (ODS) safety shutoff system. The ODS/pilot is a required feature for vent-free room fireplaces. The ODS/pilot shuts off the fireplace if there is not enough fresh air.

PIEZO IGNITION SYSTEM

This fireplace has a piezo igniter. This system requires no matches, batteries or other sources to light fireplace.

THERMOSTATIC HEAT CONTROL FOR THERMOSTAT-CONTROLLED MODELS

Thermostat-Controlled models have a thermostat sensing bulb and a control valve. The thermostat will automatically modulate the heat output to maintain a consistent room temperature. This results in greater fireplace comfort. This can also result in lower gas bills.

UNPACKING

1. Remove fireplace and hood from carton. Log is wrapped and inside fireplace. Do not remove at this time.
2. Remove all protective packaging applied to fireplace for shipment.
3. Make sure your fireplace includes one hardware packet.
4. Check fireplace for any shipping damage. If fireplace is damaged, contact IHP at Comfortflame.US.com for replacement parts before returning to dealer.

HOOD ASSEMBLY

⚠ WARNING: Always have screen in place before operating fireplace. This prevents excessive temperatures on fireplace surfaces.

⚠ WARNING: Failure to position the parts in accordance with these diagrams or failure to use only parts specifically approved with this fireplace may result in property damage or personal injury.

Tools Required:

- Phillips screwdriver
 - slotted screwdriver
 - 5/16" hex wrench
 - scissors
1. If equipped, lift fireplace screen up and pull out to remove (see Figure 2). Set screen aside until installation has been completed.
 2. Cut two plastic straps to remove log from firebox cavity. Set log aside.
 3. An optional blower is available. See [Accessories](#), page 32. Install optional blower now. Follow installation instructions provided with blower.
 4. Locate four black Phillips sheet metal screws in hardware packet.
 5. Slide hood between louver and firebox top and align screw holes.
 6. Insert screws as shown in Figure 3. Tighten screws firmly.

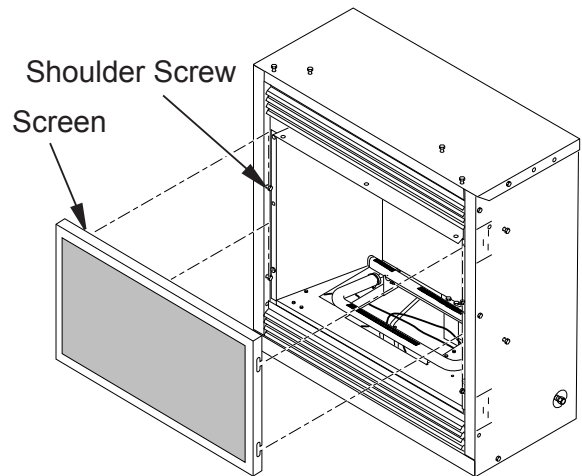

Figure 2 - Removing and Installing Screen

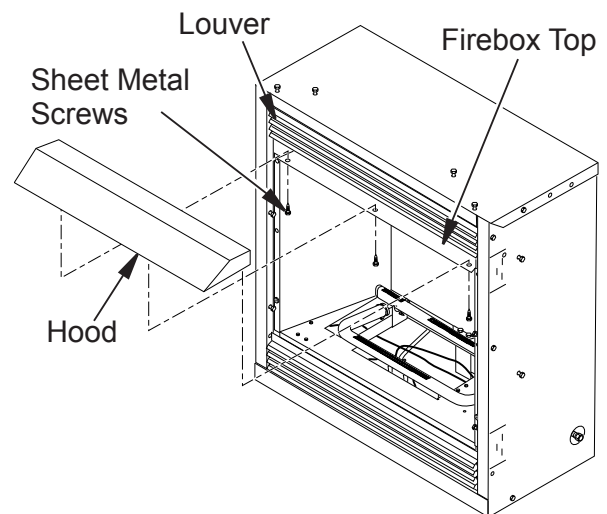

Figure 3 - Assembling Hood

AIR FOR COMBUSTION AND VENTILATION

⚠ WARNING: This heater shall not be installed in a room or space unless the required volume of indoor combustion air is provided by the method described in the National Fuel Gas Code, ANSI Z223.1/NFPA 54, the International Fuel Gas Code, or applicable local codes. Read the following instructions to insure proper fresh air for this and other fuel-burning appliances in your home.

Today's homes are built more energy efficient than ever. New materials, increased insulation and new construction methods help reduce heat loss in homes. Home owners weather strip and caulk around windows and doors to keep the cold air out and the warm air in. During heating months, home owners want their homes as airtight as possible.

While it is good to make your home energy efficient, your home needs to breathe. Fresh air must enter your home. All fuel-burning appliances need fresh air for proper combustion and ventilation.

Exhaust fans, fireplaces, clothes dryers and fuel burning appliances draw air from the house to operate. You must provide adequate fresh air for these appliances. This will insure proper venting of vented fuel-burning appliances.

PROVIDING ADEQUATE VENTILATION

The following are excerpts from National Fuel Gas Code, ANSI Z223.1/NFPA 54, Air for Combustion and Ventilation.

All spaces in homes fall into one of the three following ventilation classifications:

1. Unusually Tight Construction
2. Unconfined Space
3. Confined Space

The information on pages 6 through 7 will help you classify your space and provide adequate ventilation.

Unusually Tight Construction

The air that leaks around doors and windows may provide enough fresh air for combustion and ventilation. However, in buildings of unusually tight construction, you must provide additional fresh air.

Unusually tight construction is defined as construction where:

- a. walls and ceilings exposed to the outside atmosphere have a continuous water vapor retarder with a rating of one perm (6×10^{-11} kg per pa-sec- m^2) or less with openings gasketed or sealed **and**
- b. weather stripping has been added on openable windows and doors **and**
- c. caulking or sealants are applied to areas such as joints around window and door frames, between sole plates and floors, between wall-ceiling joints, between wall panels, at penetrations for plumbing, electrical and gas lines and at other openings.

If your home meets all of these three criteria, you must provide additional fresh air. See *Ventilation Air From Outdoors*, page 7.

If your home does not meet all of the three criteria above, proceed to *Determining Fresh-Air Flow For Fireplace Location*.

Confined and Unconfined Space

The National Fuel Gas Code, ANSI Z223.1/NFPA 54 defines a confined space as a space whose volume is less than 50 cubic feet per 1,000

Btu/hr (4.8 m³ per kw) of the aggregate input rating of all appliances installed in that space and an unconfined space as a space whose volume is not less than 50 cubic feet per 1,000 Btu/hr (4.8 m³ per kw) of the aggregate input rating of all appliances installed in that space. Rooms communicating directly with the space in which the appliances are installed*, through openings not furnished with doors, are considered a part of the unconfined space.

* Adjoining rooms are communicating only if there are doorless passageways or ventilation grills between them.

DETERMINING FRESH-AIR FLOW FOR FIREPLACE LOCATION

Determining if You Have a Confined or Unconfined Space

Use this work sheet to determine if you have a confined or unconfined space.

Space: Includes the room in which you will install fireplace plus any adjoining rooms with doorless passageways or ventilation grills between the rooms.

1. Determine the volume of the space (length x width x height).
Length x Width x Height = _____ cu. ft. (volume of space)
Example: Space size 16 ft. (length) x 14 ft. (width) x 8 ft. (ceiling height) = 1792 cu. ft. (volume of space)
If additional ventilation to adjoining room is supplied with grills or openings, add the volume of these rooms to the total volume of the space.

2. Multiply the space volume by 20 to determine the maximum Btu/Hr the space can support.

_____ (volume of space) x 20 = (Maximum Btu/Hr the space can support)

Example: 1792 cu. ft. (volume of space) x 20 = 35,840 (maximum Btu/Hr the space can support)

3. Add the Btu/Hr of all fuel burning appliances in the space.

Vent-free fireplace _____ Btu/Hr
Gas water heater* _____ Btu/Hr
Gas furnace _____ Btu/Hr
Vented gas heater _____ Btu/Hr
Gas fireplace logs _____ Btu/Hr
Other gas appliances* + _____ Btu/Hr
Total = _____ Btu/Hr

* Do not include direct-vent gas appliances. Direct-vent draws combustion air from the outdoors and vents to the outdoors.

Example:

Gas water heater 30,000 Btu/Hr
Vent-free fireplace + 10,000 Btu/Hr
Total = 40,000 Btu/Hr

4. Compare the maximum Btu/Hr the space can support with the actual amount of Btu/Hr used.

_____ Btu/Hr (maximum space can support)

_____ Btu/Hr (actual amount used)

Example: 35,840 Btu/Hr (maximum the space can support)

40,000 Btu/Hr (actual amount of Btu/Hr used)

The space in the previous example is a confined space because the actual Btu/Hr used is more than the maximum Btu/Hr the space can support. You must provide additional fresh air. Your options are as follows:

AIR FOR COMBUSTION AND VENTILATION *Continued*

- Rework worksheet, adding the space of an adjoining room. If the extra space provides an unconfined space, remove door to adjoining room or add ventilation grills between rooms. See [Ventilation Air From Inside Building](#).
- Vent room directly to the outdoors. See [Ventilation Air From Outdoors](#).
- Install a lower Btu/Hr fireplace, if lower Btu/Hr size makes room unconfined.

If the actual Btu/Hr used is less than the maximum Btu/Hr the space can support, the space is an unconfined space. You will need no additional fresh air ventilation.

⚠ WARNING: If the area in which the heater may be operated does not meet the required volume for indoor combustion air, combustion and ventilation air shall be provided by one of the methods described in the National Fuel Gas Code, ANSI Z223.1/NFPA 54, the International Fuel Gas Code, or applicable local codes.

VENTILATION AIR

Ventilation Air From Inside Building

This fresh air would come from an adjoining unconfined space. When ventilating to an adjoining unconfined space, you must provide two permanent openings: one within 12" of the ceiling and one within 12" of the floor on the wall connecting the two spaces (see options 1 and 2, Figure 4). You can also remove door into adjoining room (see option 3, Figure 4). Follow the National Fuel Gas Code, ANSI Z223.1/NFPA 54, Air for Combustion and Ventilation for required size of ventilation grills or ducts.

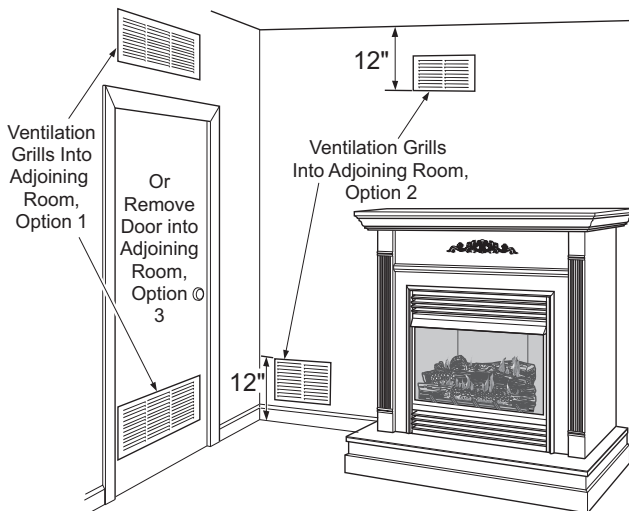

Figure 4 - Ventilation Air from Inside Building

Ventilation Air From Outdoors

Provide extra fresh air by using ventilation grills or ducts. You must provide two permanent openings: one within 12" of the ceiling and one within 12" of the floor. Connect these items directly to the outdoors or spaces open to the outdoors. These spaces include attics and crawl spaces. Follow the National Fuel Gas Code, ANSI Z223.1/NFPA 54, Air for Combustion and Ventilation for required size of ventilation grills or ducts.

IMPORTANT: Do not provide openings for inlet or outlet air into attic if attic has a thermostat-controlled power vent. Heated air entering the attic will activate the power vent.

⚠ WARNING: A qualified service person must install fireplace. Follow all local codes.

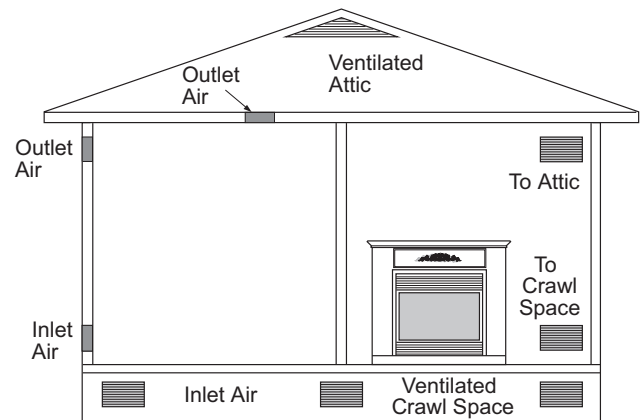

Figure 5 - Ventilation Air from Outdoors

INSTALLATION

NOTICE: This heater is intended for use as supplemental heat. Use this heater along with your primary heating system. Do not install this heater as your primary heat source. If you have a central heating system, you may run system's circulating blower while using heater. This will help circulate the heat throughout the house. In the event of a power outage, you can use this heater as your primary heat source.

⚠ WARNING: Never install the fireplace

- in a bedroom or bathroom
- in a recreational vehicle
- where curtains, furniture, clothing or other flammable objects are less than 36" from the front, top or sides of the fireplace
- as a fireplace insert
- in high traffic areas
- in windy or drafty areas

⚠ WARNING: Never install in a bedroom or bathroom. Any heating product with a Btu/Hr rating over 10,000 cannot be used in a bedroom.

⚠ CAUTION: This fireplace creates warm air currents. These currents move heat to wall surfaces next to fireplace. Installing fireplace next to vinyl or cloth wall coverings or operating fireplace where impurities (such as, but not limited to, tobacco smoke, aromatic candles, cleaning fluids, oil or kerosene lamps, etc.) in the air exist, may discolor walls or cause odors.

IMPORTANT: Vent-free fireplaces add moisture to the air. Although this is beneficial, installing fireplace in rooms without enough ventilation air may cause mildew to form from too much moisture. See [Air for Combustion and Ventilation](#), page 6.

Note: Your fireplace is designed to be used in zero clearance installations. Wall or framing material can be placed directly against any exterior surface on the rear, sides or top of your fireplace, except where standoff spacers are integrally attached. If standoff spacers are attached to your fireplace, these spacers can be placed directly against wall or framing materials.

Note: When installing fireplace directly on carpeting, tile or other combustible material, other than wood flooring, the fireplace shall be installed on a metal or wood panel extending the full width and depth of the fireplace.

Use the dimensions shown for rough openings to create the easiest installation (see [Built-In Fireplace Installation](#), page 9).

CHECK GAS TYPE

Use the correct gas type (natural or propane/LP) for your unit. If your gas supply is not correct, do not install fireplace. Call dealer where you bought fireplace for proper type fireplace.

⚠ WARNING: This appliance is equipped for either natural gas or propane/LP gas but not both. Gas type is indicated on the rating plate. Field conversion is not permitted.

INSTALLATION ITEMS

Before installing fireplace, make sure you have the items listed below.

- external regulator (supplied by installer, for propane/LP units only)
- piping (check local codes)
- sealant (resistant to propane/LP gas)
- equipment shutoff valve *
- test gauge connection *
- ground joint union
- sediment trap
- tee joint
- pipe wrench

* An equipment shutoff valve with 1/8" NPT tap is an acceptable alternative to test gauge connection. Purchase the optional equipment shutoff valve from your dealer. See [Accessories](#), page 32.

Note: If desired, purchase a four-sided perimeter trim kit for built-in installations. See [Accessories](#), page 32.

FIREPLACE CLEARANCES

⚠ WARNING: Maintain the minimum clearances shown in Figure 7. If you can, provide greater clearances from floor, ceiling and joining wall.

If your fireplace is to be used with an optional mantel, the installation instructions included with your mantel shows an approved method of attaching the fireplace/mantel system to a wall. **IMPORTANT:** Only use optional cabinet or corner mantels specified in this manual. Purchase the optional mantel from your dealer (see [Accessories](#), page 32).

If your fireplace is to be recessed into the wall, see [Built-In Fireplace Installation](#) on page 9 to secure your fireplace into the wall.

⚠ CAUTION: If you install the fireplace in a home garage

- fireplace pilot and burner must be at least 18" above floor.
- locate fireplace where moving vehicle will not hit it.

For convenience and efficiency, install fireplace

- where there is easy access for operation, inspection and service
- in coldest part of room

An optional blower kit is available from your dealer. See [Accessories](#), page 32. If planning to use blower, follow instructions provided with blower for power source.

INSTALLATION *Continued*

Minimum Clearances For Side Combustible Material, Side Wall and Ceiling

A. Clearances from the side of the fireplace cabinet to any combustible material and wall should follow diagram in Figure 6.

Example: The face of a mantel, bookshelf, etc. is made of combustible material and protrudes 3 1/2" from the wall. This combustible material must be 4" from the side of the fireplace opening (see Figure 6).

B. Clearances from the top of the fireplace opening to the ceiling should not be less than 36".

C. For mantel clearances, see Figure 10 on page 10.

MINIMUM CLEARANCE TO COMBUSTIBLE MATERIALS

Top 36", Left and Right Sides 6",
Bottom and Rear 0", Front 36"

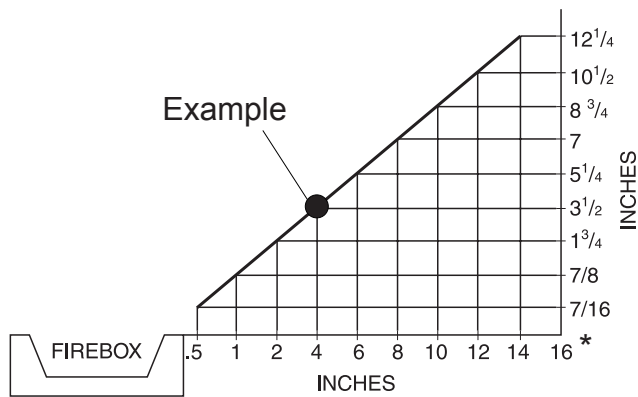

*Minimum 16" from Side Wall

Figure 6 - Minimum Clearance for Combustible to Wall

BUILT-IN FIREPLACE INSTALLATION

Built-in installation of this fireplace involves installing fireplace into a framed-in enclosure. This makes the front of fireplace flush with wall. An optional trim kit accessory is available (see *Accessories*, page 32). Trim will extend past sides of fireplace approximately 1/2". This will cover the rough edges of the wall opening. If installing a built-in mantel above the fireplace, you must follow the clearances shown in Figure 9, page 10. Follow the instructions below to install the fireplace in this manner.

	Actual	Framing
Height	26"	26 7/8"
Front Width	26 3/4"	26 7/8"
Depth	14 1/4"	15 1/4"

1. Frame in rough opening. Use dimensions shown in Figure 7, for the rough opening. If installing in a corner, use dimensions shown in Figure 8, for the rough opening. The height is 26 7/8" which is the same as the wall opening above.

2. If installing GA3450TA blower accessory, do so at this time. Follow instructions included with blower accessory.

Note: If not installing blower accessory, you may wish to run electrical wiring to your fireplace for future blower installation (see *Accessories*, page 32). Use only approved three-wire electrical wiring.

⚠ WARNING: If pre-wiring, do not connect wiring to any electrical source at this time.

Install fireplace electrical outlet and connect wiring to outlet before connecting to electrical source. The fireplace electrical outlet is included with the GA3450TA blower accessory.

Only use the fireplace electrical outlet supplied with the GA3450TA blower accessory.

Note: A qualified installer should make all electrical connections.

3. Install gas piping to fireplace location. This installation includes an approved flexible gas line (if allowed by local codes) after the equipment shutoff valve. The flexible gas line must be the last item installed on the gas piping.

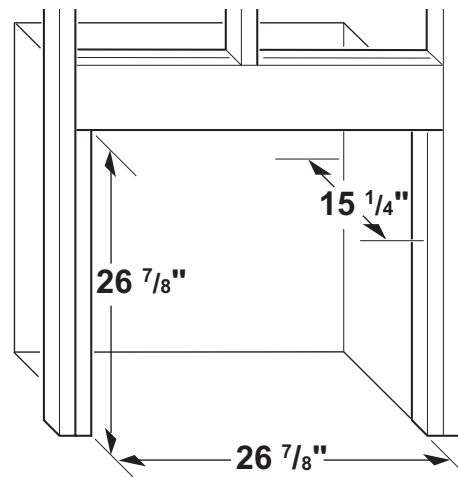

Figure 7 - Rough Opening for Installing in Wall

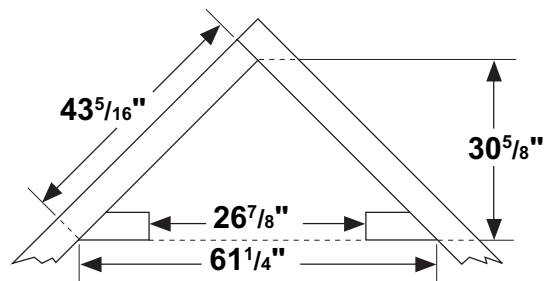

Figure 8 - Rough Opening for Installing in Corner

INSTALLATION *Continued*

4. If you have not installed hood, follow instructions on page 6.
5. Carefully set fireplace in front of rough opening with back of fireplace inside wall opening.
6. Attach flexible gas line to fireplace gas regulator. See [Connecting Equipment Shutoff Valve to Heater Control](#), page 12.
7. Bend four nailing flanges on outer casing with pliers (see Figure 9).
8. Attach fireplace to wall studs using nails or wood screws through holes in nailing flange.
9. Check all gas connections for leaks. See [Checking Gas Connections](#), page 13.
10. If using optional trim kit, install the trim after final finishing and/or painting of wall. See instructions included with trim accessory for attaching trim.

IMPORTANT: When finishing your firebox, combustible materials such as wall board, gypsum board, sheet rock, drywall, plywood, etc. may be butted up next to the sides and top edge of the firebox. Combustible materials should never overlap the firebox front facing.

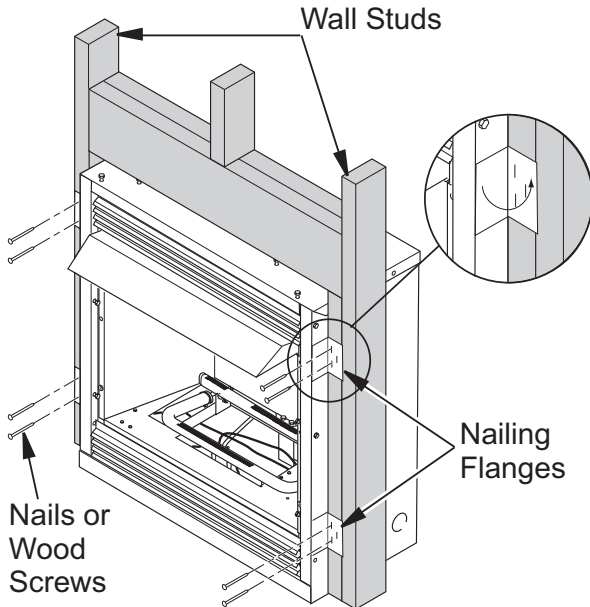

Figure 9 - Attaching Fireplace to Wall Studs

WARNING: Do not allow any combustible/noncombustible materials to overlap the firebox front facing.

WARNING: Do not allow combustible or noncombustible materials to cover any necessary openings like louvered slots.

WARNING: Never modify or cover the louvered slots on the front of the firebox.

Mantel Clearances for Built-In Installation

If placing mantel above built-in fireplace, you must meet minimum clearance between mantel shelf and top of fireplace opening.

NOTICE: Surface temperatures of adjacent walls and mantels become hot during operation. Walls and mantels above the firebox may become hot to the touch. If installed properly, these temperatures meet the requirement of the national product standard. Follow all minimum clearances shown in this manual.

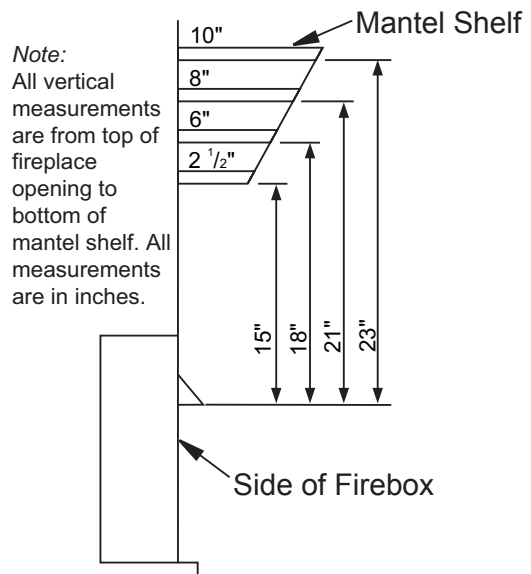

Figure 10 - Minimum Mantel Clearances for Built-In Installation

NOTICE: If your installation does not meet the minimum clearances shown, you must do one of the following:

- raise the mantel to an acceptable height
- remove the mantel

INSTALLATION *Continued*

REMOVING UPPER LOUVER

To install mantel or blower accessory, you must first remove the upper louver.

1. Lift screen off fireplace and remove log set if installed.
2. Remove 4 screws from upper louver (see Figure 11). Save these screws.
3. Pull upper louver straight out from the cabinet. Be careful not to scratch the paint. Set louver aside.
4. Open lower louver door by swinging door down (see Figure 11).

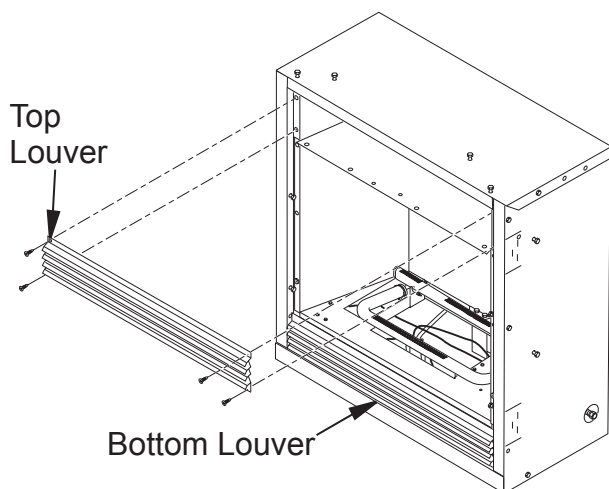

Figure 11 - Removing Top Louver and Opening Bottom Louver

OPTIONAL MANTEL INSTALLATION

Refer to instructions provided with the mantel for assembly instructions.

INSTALLING OPTIONAL BLOWER ACCESSORY GA3450TA (J1281)

Refer to instructions provided with the blower for assembly instructions.

CONNECTING TO GAS SUPPLY

⚠ WARNING: This appliance requires a 45° male flare fitting 5/8"-18 UNF (Unified National Fine Thread) inlet connection and the flexible gas line provided.

⚠ WARNING: A qualified service person must connect fireplace to gas supply. Follow all local codes.

⚠ WARNING: Never connect natural gas fireplace to private (non-utility) gas wells. This gas is commonly known as wellhead gas.

IMPORTANT: For natural gas, check gas line pressure before connecting fireplace to gas line. Gas line pressure must be no greater than 14" of water. If gas line pressure is higher, heater regulator damage could occur.

⚠ CAUTION: Never connect propane/LP fireplace directly to the propane/LP supply. This fireplace requires an external regulator (not supplied). Install the external regulator between the fireplace and propane/LP supply.

For propane/LP units, the installer must supply an external regulator. The external regulator will reduce incoming gas pressure. You must reduce incoming gas pressure to between 11" and 14" of water. If you do not reduce incoming gas pressure, fireplace regulator damage could occur. Install external regulator with the vent pointing down as shown in Figure 12, page 12. Pointing the vent down protects it from freezing rain or sleet.

⚠ CAUTION: Use only new, black iron or steel pipe. Internally-tinned copper tubing may be used in certain areas. Check your local codes. Use pipe of 1/2" or greater diameter to allow proper gas volume to fireplace. If pipe is too small, undue loss of volume will occur.

Installation must include an equipment shutoff valve, union and plugged 1/8" NPT tap. Locate NPT tap within reach for test gauge hook up. NPT tap must be upstream from heater (see Figure 13, page 12).

IMPORTANT: Install equipment shutoff valve in an accessible location. The equipment shutoff valve is for turning on or shutting off the gas to the appliance.

Check your building codes for any special requirements for locating equipment shutoff valve to fireplaces.

Apply pipe joint sealant lightly to male NPT threads. This will prevent excess sealant from going into pipe. Excess sealant in pipe could result in clogged fireplace valves.

INSTALLATION *Continued*

⚠ WARNING: Use pipe joint sealant that is resistant to liquid petroleum (LP) gas.

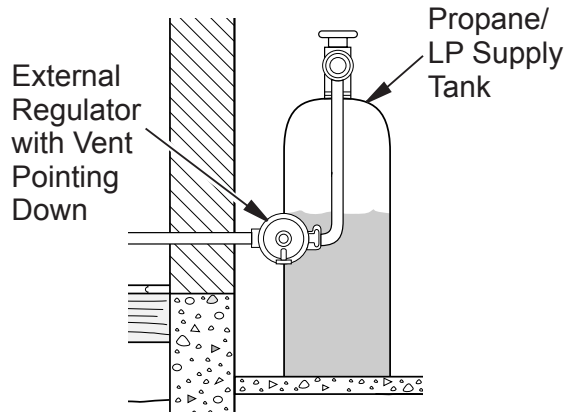
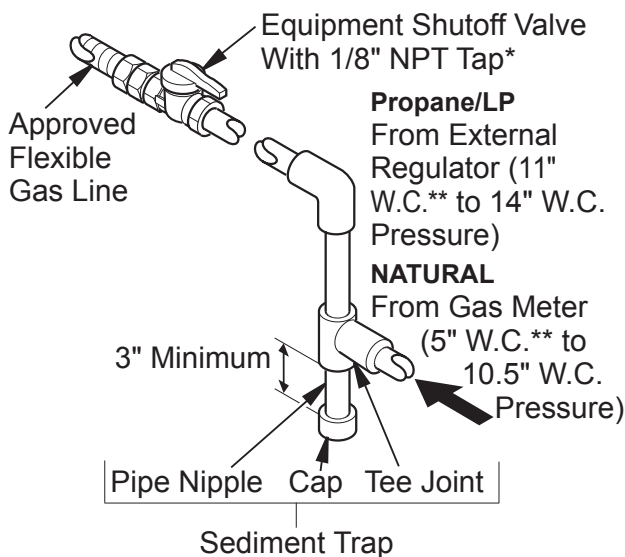

Figure 12 - External Regulator With Vent Pointing Down

We recommend that you install a sediment trap in supply line as shown in Figure 13. Locate sediment trap where it is within reach for cleaning. Install in piping system between fuel supply and heater. Locate sediment trap where trapped matter is not likely to freeze. A sediment trap traps moisture and contaminants. This keeps them from going into fireplace controls. If sediment trap is not installed or is installed wrong, fireplace may not run properly.



* Purchase the optional equipment shutoff valve from your dealer. See [Accessories](#), page 32.

Figure 13 - Gas Connection

CONNECTING EQUIPMENT SHUTOFF VALVE TO HEATER CONTROL

Installation Items Needed

- Phillips screwdriver
 - sealant (resistant to propane/LP gas, not provided)
1. Open lower louver (see Figure 14).

NOTICE: Most building codes do not permit concealed gas connections. A flexible gas line is provided to allow accessibility from the fireplace (see Figure 13). The flexible gas supply line connection to the equipment shutoff valve should be accessible.

2. Route flexible gas line, included, from fireplace control to equipment shutoff valve through side access holes in outer casing.
3. Apply pipe joint sealant lightly to male threads of gas connector attached to flexible gas line/equipment shutoff valve (see Figure 15).

⚠ CAUTION: Avoid damage to regulator. Hold gas regulator with wrench when connecting it to gas piping and/or fittings (Thermostat-Controlled Models Only).

⚠ CAUTION: Avoid damage to gas control. Hold gas control with wrench when connecting it to gas piping and/or fittings (Remote-Ready Models Only).

4. Check all gas connections for leaks. See [Checking Gas Connections](#), page 13. Feed flexible gas line into fireplace. Make sure the entire flexible gas line is in fireplace (see Figure 14).

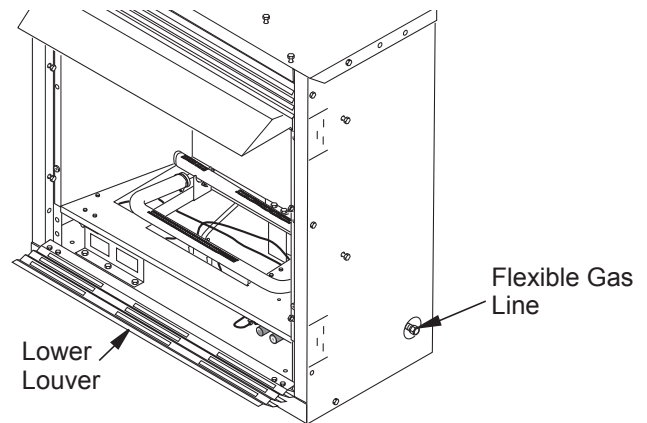

Figure 14 - Flexible Gas Line Location (Remote-Ready Unit Shown)

To Gas Regulator (Thermostat-Controlled Models)
or Control Valve (Remote-Ready Models)

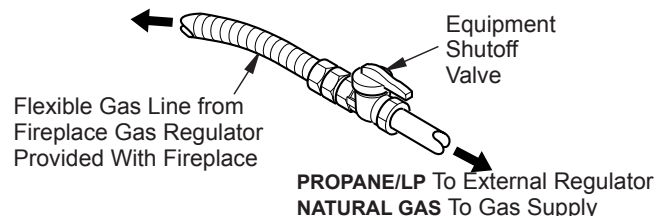

Figure 15 - Attaching Flexible Gas Line to Equipment Shutoff Valve

INSTALLATION *Continued*

CHECKING GAS CONNECTIONS

⚠ WARNING: Test all gas piping and connections, internal and external to unit, for leaks after installing or servicing. Correct all leaks at once.

⚠ WARNING: Never use an open flame to check for a leak. Apply a noncorrosive leak detection fluid to all joints. Bubbles forming show a leak. Correct all leaks at once.

⚠ CAUTION: Make sure external regulator has been installed between propane/LP supply and fireplace. See guidelines under Connecting to Gas Supply, page 11.

PRESSURE TESTING GAS SUPPLY PIPING SYSTEM

Test Pressures In Excess Of 1/2 PSIG (3.5 kPa)

The appliance and its appliance main gas valve must be disconnected from the gas supply piping system during any pressure testing of that system at test pressures **in excess of** 1/2 psig (3.5 kPa).

1. Disconnect appliance with its appliance main gas valve (control valve) and equipment shutoff valve from gas supply piping system. Pressures in excess of 1/2 psig (3.5kPa) will damage heater regulator.
2. Cap off open end of gas pipe where equipment shutoff valve was connected.
3. Pressurize supply piping system by either opening propane/LP supply tank valve for propane/LP gas or opening main gas valve located on or near gas meter for natural gas or using compressed air.
4. Check all joints of gas supply piping system. Apply noncorrosive leak detection fluid to all joints. Bubbles forming show a leak.
5. Correct all leaks at once.
6. Reconnect fireplace and equipment shutoff valve to gas supply. Check reconnected fittings for leaks.

Test Pressures Equal To or Less Than 1/2 PSIG (3.5 kPa)

The appliance must be isolated from the gas supply piping system by closing its equipment shutoff valve during any pressure testing of the gas supply piping system at test pressures **equal to or less than** 1/2 psig (3.5 kPa).

1. Close equipment shutoff valve (see Figure 16).
2. Pressurize supply piping system by either opening propane/LP supply tank valve for propane/LP gas or opening main gas valve located on or near gas meter for natural gas or using compressed air.

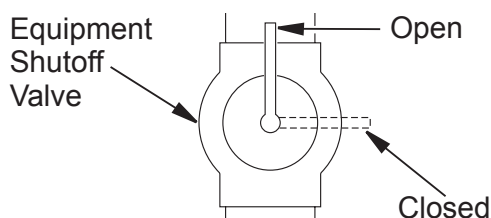

Figure 16 - Equipment Shutoff Valve

3. Check all joints from gas meter to equipment shutoff valve for natural gas or propane/LP supply to equipment shutoff valve for propane/LP (see Figures 17 or 18). Apply noncorrosive leak detection fluid to all joints. Bubbles forming show a leak.
4. Correct all leaks at once.

PRESSURE TESTING FIREPLACE GAS CONNECTIONS

1. Open equipment shutoff valve (see Figure 16).
2. Open main gas valve located on or near gas meter for natural gas or open propane/LP supply tank valve.
3. Make sure control knob of fireplace is in the OFF position.
4. Check all joints from equipment shutoff valve to gas regulator (Thermostat-Controlled Models) or to gas control valve (Remote-Ready Models) (see Figures 17 or 18). Apply noncorrosive leak detection fluid to all joints. Bubbles forming show a leak.
5. Correct all leaks at once.
6. Light fireplace (see Operation, page 16). Check all other internal joints for leaks.
7. Turn off fireplace (see To Turn Off Gas to Appliance, page 17 for Thermostat-Controlled Models or page 19 for Remote-Ready Models).

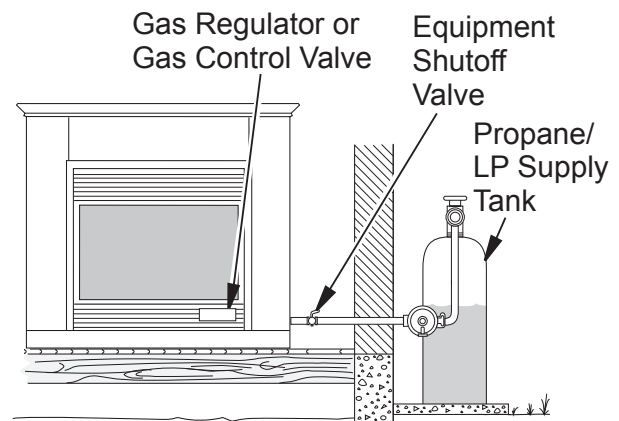

Figure 17 - Checking Gas Joints (Propane/LP Only)

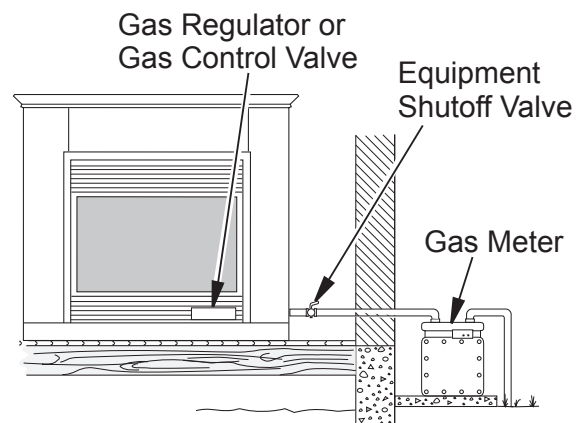

Figure 18 - Checking Gas Joints (Natural Gas Only)

INSTALLATION *Continued*

OPTIONAL WIRELESS HAND-HELD REMOTE CONTROL ACCESSORIES

Remote-Ready Models Only (MRC - F1077 and TRC - F1078)

Installing Receiver

1. Disconnect jumper wires from the control valve (see Figure 19).
2. Locate the battery cover on the back of the receiver (see Figure 20).
3. Install 4-AA batteries (included) into receiver before installing into fireplace.
4. Connect wires from remote receiver to control valve. See instructions provided with remote control kit for further information.

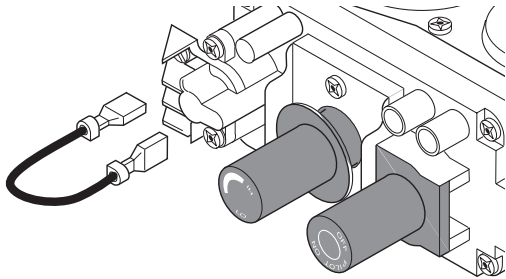

Figure 19 - Disconnecting Jumper Wires From Control Valve

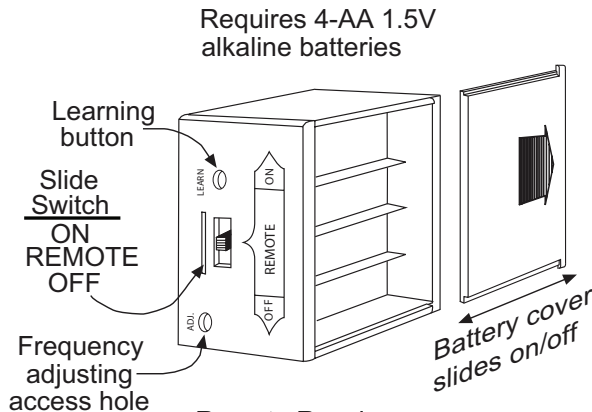

Figure 20 - Attaching Batteries to Receiver

OPTIONAL WALL MOUNTED THERMOSTAT - GWMT1 (F0240) (Remote-Ready Models Only)

⚠ WARNING: Read and follow installation instructions. Installation should be done by a qualified installer familiar with low-voltage wiring procedures.

⚠ WARNING: Do not connect this thermostat to any electrical source! Electrical shock and/or fire hazard will occur.

1. Remove jumper wire from control valve (see Figure 19).
2. Connect one terminal of 25 ft. wire to the "TH" terminal on the control valve. Connect the other terminal to the "THTP" terminal on the control valve. See Figure 21, page 15.

3. Route the 25 ft. wire to a convenient location to mount your thermostat (no outside wall). **IMPORTANT:** The wire may be shortened but must not be lengthened.

The thermostat should be mounted 54" above the floor in a location where there is good air circulation. Avoid heat sources such as lamps, direct sunlight, fireplace or heat and air conditioning ducts.

4. Gently remove cover of thermostat from base. Grasp sides of cover firmly and pull to separate from base.
5. Feed electrical wires through rectangular slots on each side of base (see Figure 22).

⚠ WARNING: Do not connect the thermostat to a power source. Electrical shock and/or a fire hazard will occur.

6. Connect one bare wire end to each terminal ("W" and "R") of the thermostat base (see Figure 23).

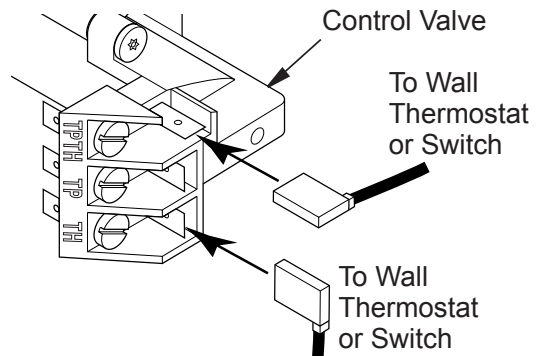

Figure 21 - Connecting Wire Terminals

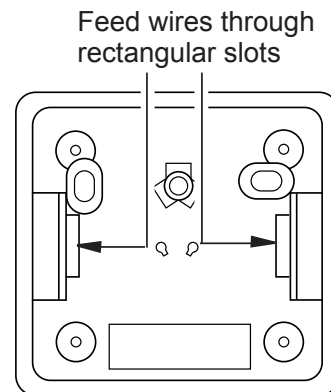

Figure 22 - Back View of Thermostat Base

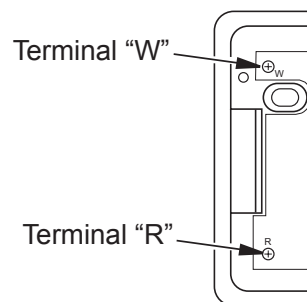

Figure 23 - Thermostat Base Terminals "W" and "R"

INSTALLATION *Continued*

7. Install base onto wall with provided screws.
8. Move temperature adjustment back and forth to insure the bimetal is free from restrictions.
9. Replace cover onto base. (Upon installation, thermostat must be allowed to stabilize at room temperature for a minimum of 30 minutes for proper operation).
10. Set temperature adjustment to desired setting. This thermostat has been electronically calibrated at the factory. No adjustment or leveling is necessary.

OPTIONAL WALL SWITCH - GMWS2 (F0245)

(Remote-Ready Models Only)

⚠ WARNING: Read and follow installation instructions. Installation should be done by a qualified installer familiar with low-voltage wiring procedures.

⚠ WARNING: Do not connect this switch to any electrical source! Electrical shock and/or fire hazard will occur.

1. Remove jumper wire from control valve (see Figure 19, page 16).
2. Connect one terminal of 25 ft. wire to the "TH" terminal on the control valve. Connect other terminal to the "THTP" terminal on control valve. See Figure 21, page 14.
3. Route the 25 ft. wire to a convenient location to mount your wall switch (no outside walls).

⚠ WARNING: Do not connect the switch to a power source. Electrical shock and/or fire hazard will occur.

IMPORTANT: The wire may be shortened but must not be lengthened.

4. Connect one bare wire end to each of the terminals of the provided wall switch.
5. Install the wall switch and cover in the wall.

INSTALLING LOG SET AND SCREEN

1. Remove log packaging material and discard packaging. Gently place log over burner (see Figure 24). Do not allow log to contact flame. If flame contacts log, soot will be created.
2. Reattach screen by placing notches in screen frame over shoulder screws and pushing down.

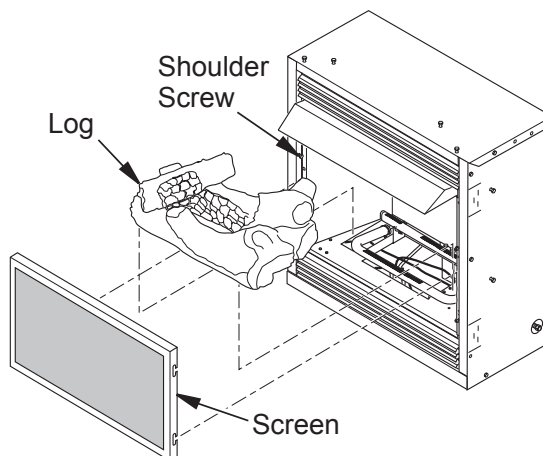

Figure 24 - Installing Log and Screen

OPERATION

THERMOSTAT-CONTROLLED MODELS

**FOR YOUR SAFETY
READ BEFORE LIGHTING**

⚠ WARNING: If you do not follow these instructions exactly, a fire or explosion may result causing property damage, personal injury or loss of life.

- A. This appliance has a pilot which must be lighted by hand. When lighting the pilot, follow these instructions exactly.
- B. **BEFORE LIGHTING** smell all around the appliance area for gas. Be sure to smell next to the floor because some gas is heavier than air and will settle on the floor.
WHAT TO DO IF YOU SMELL GAS
 - Do not try to light any appliance.
 - Do not touch any electric switch; do not use any phone in your building.
 - Immediately call your gas supplier from a neighbor's phone. Follow the gas supplier's instructions.
 - If you cannot reach your gas supplier, call the fire department.
- C. Use only your hand to push in or turn the gas control knob. Never use tools. If the knob will not push in or turn by hand, don't try to repair it, call a qualified service technician or gas supplier. Force or attempted repair may result in a fire or explosion.
- D. Do not use this appliance if any part has been under water. Immediately call a qualified service technician to inspect the appliance and to replace any part of the control system and any gas control which has been under water.

**LIGHTING
INSTRUCTIONS**

⚠ WARNING: You must operate this fireplace with the screen in place. Make sure fireplace screen is installed before running fireplace.

NOTICE: During initial operation of new fireplace, burning logs will give off a paper-burning smell. Open window to vent smell. Operate fireplace on HI position to burn off odor. This will only last a few hours.

1. STOP! Read the safety information starting in column 1, above.
2. Make sure equipment shutoff valve is fully open.
3. Turn control knob clockwise ↻ to the OFF position.
4. Wait five (5) minutes to clear out any gas. Then smell for gas, including near the floor. If you smell gas, STOP! Follow "B" in the safety information, above. If you don't smell gas, go to the next step.
5. Turn control knob counterclockwise ↻ to the PILOT position. Press in control knob for five (5) seconds (see Figure 25).
Note: You may be running this fireplace for the first time after hooking up to gas supply. If so, the control knob may need to be pressed in for 30 seconds or more. This will allow air to bleed from the gas system.

- If control knob does not pop out when released, contact a qualified service person or gas supplier for repairs.
6. With control knob pressed in, press and release igniter button. This will light pilot. The pilot is attached to the front burner. If needed, keep pressing igniter button until pilot lights.
Note: If pilot does not stay lit, refer to [Troubleshooting](#), page 22. Also, contact a qualified service person or gas supplier for repairs. Until repairs are made, light pilot with match. To light pilot with match, see [Manual Lighting Procedure](#), page 17.
 7. Keep control knob pressed in for 30 seconds after lighting pilot. After 30 seconds, release control knob.
Note: If pilot goes out, repeat steps 3 through 7. This fireplace has a safety interlock system. Wait one (1) minute for system to reset before lighting pilot again.

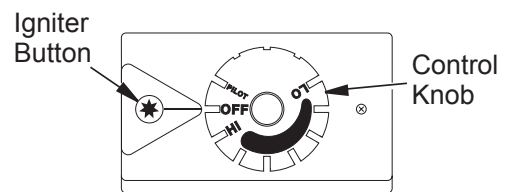

Figure 25 - Control Knob In The OFF Position

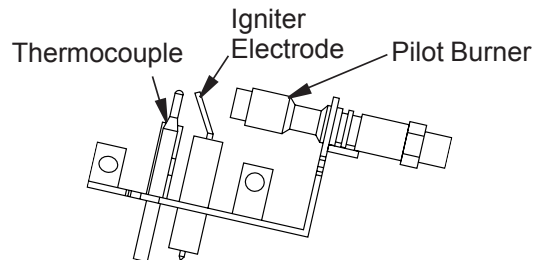

Figure 26 - Natural Gas Pilot

8. Turn control knob counterclockwise ↻ to desired heating level. The burner should light. Set control knob to any heat level between HI and LO.
9. To leave pilot lit and shut off burners only, turn control knob clockwise ↻ to the PILOT position.

⚠ CAUTION: Do not try to adjust heating levels by using the equipment shutoff valve.

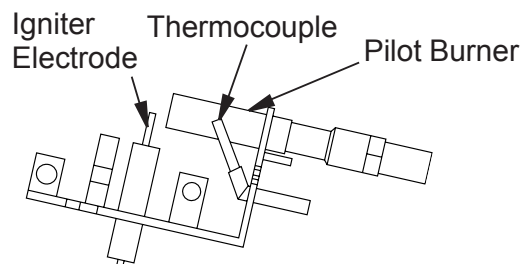



Figure 27 - Propane/LP Gas Pilot

OPERATION *Continued*

THERMOSTAT-CONTROLLED MODELS

TO TURN OFF GAS TO APPLIANCE

Shutting Off Fireplace

1. Turn control knob clockwise  to the OFF position.
2. Turn off all electric power to the appliance (if applicable) if service is to be performed.
3. Close equipment shutoff valve (see Figure 16, page 13).

THERMOSTAT CONTROL OPERATION

The thermostat used on this fireplace senses the room temperature. At times the room may exceed the set temperature. If so, the burner will shut off. The burner will cycle back on when room temperature drops below the set temperature.

The control knob can be set to any heat level between HI and LO.

Note: The thermostat sensing bulb measures the air near the fireplace cabinet. This may not always agree with room temperature (depending on housing construction, installation location, room size, open air temperatures, etc.). Frequent use of your fireplace will let you determine your own comfort levels.

MANUAL LIGHTING PROCEDURE

1. Follow steps 1 through 5 under Lighting Instructions, beginning on page 16.
2. With control knob pressed in, strike match. Hold match to pilot until pilot lights.
3. Keep control knob pressed in for 30 seconds after lighting pilot. After 30 seconds, release control knob. Now follow step 8 under Lighting Instructions, page 16, column 2.

OPERATING OPTIONAL BLOWER

This blower has three settings: ON, OFF and AUTO. In the ON position, the blower will operate constantly. In the OFF position, the blower will not operate. In the AUTO position, the blower will start when the thermostat senses a sufficient increase in firebox temperature.

Note: Your fireplace and thermostat blower will not turn on and off at the same time. The fireplace may run for several minutes before the blower turns on. After the heater modulates to the pilot position, the blower will continue to run. The blower will shut off after the firebox temperature decreases.

Note: It is safe to operate fireplace with blower turned off. However, the blower helps distribute heated air from the fireplace.

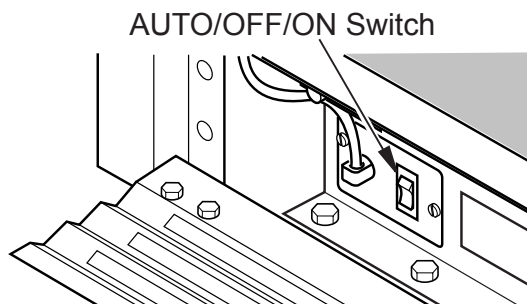

Figure 28 - AUTO/OFF/ON Blower Switch

OPERATION *Continued*

REMOTE-READY MODELS

**FOR YOUR SAFETY
READ BEFORE LIGHTING**

⚠ WARNING: If you do not follow these instructions exactly, a fire or explosion may result causing property damage, personal injury or loss of life.

A. This appliance has a pilot which must be lighted by hand. When lighting the pilot, follow these instructions exactly.

B. BEFORE LIGHTING smell all around the appliance area for gas. Be sure to smell next to the floor because some gas is heavier than air and will settle on the floor.

WHAT TO DO IF YOU SMELL GAS

- Do not try to light any appliance.
- Do not touch any electric switch; do not use any phone in your building.
- Immediately call your gas supplier from a neighbor's phone. Follow the gas supplier's instructions.
- If you cannot reach your gas supplier, call the fire department.

C. Use only your hand to push in or turn the gas control knob. Never use tools. If the knob will not push in or turn by hand, don't try to repair it, call a qualified service technician or gas supplier. Force or attempted repair may result in a fire or explosion.

D. Do not use this appliance if any part has been under water. Immediately call a qualified service technician to inspect the appliance and to replace any part of the control system and any gas control which has been under water.

5. Press in and turn control knob counterclockwise ↶ to the PILOT position. Press in control knob for five (5) seconds (see Figure 29). **Note:** You may be running this fireplace for the first time after hooking up to gas supply. If so, the control knob may need to be pressed in for 30 seconds or more. This will allow air to bleed from the gas system.

6. With control knob pressed in, press and release igniter button. This will light pilot. The pilot is attached to the front burner. If needed, keep pressing igniter button until pilot lights.

Note: If pilot does not stay lit, contact a qualified service person or gas supplier for repairs. Until repairs are made, light pilot with match. To light pilot with match, see Manual Lighting Procedure.

7. Keep control knob pressed in for 30 seconds after lighting pilot. After 30 seconds, release control knob.

• If control knob does not pop out when released, contact a qualified service person or gas supplier for repairs.

Note: If pilot goes out, repeat steps 4 through 8.

8. Slightly push in and turn control knob counterclockwise ↶ to the ON position.

9. Set flame adjustment knob to any level between HI and LO.

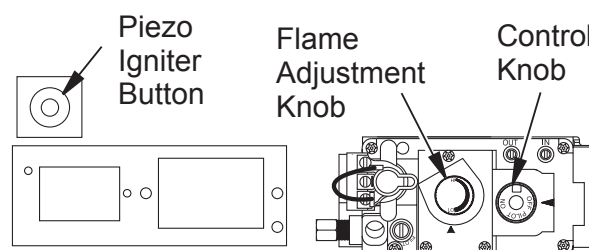

Figure 29 - Control Knob and Igniter Button Location (Shown as Supplied - No Control Options)

10. To leave pilot lit and shut off burners only, turn control knob clockwise to PILOT position. If using optional hand-held remote, use remote control manual OFF button.

⚠ CAUTION: Do not try to adjust heating levels by using the equipment shutoff valve.

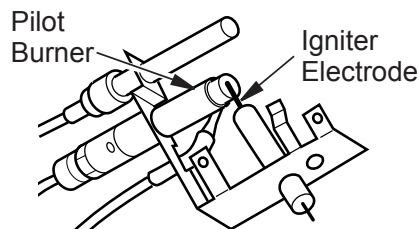

Figure 30 - Propane/LP Gas Pilot

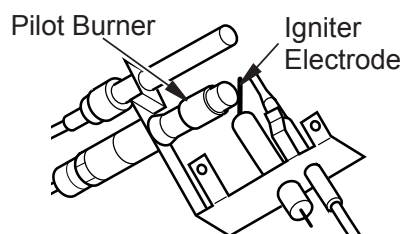

Figure 31 - Natural Gas Pilot

**LIGHTING
INSTRUCTIONS**

⚠ WARNING: You must operate this fireplace with the screen in place. Make sure fireplace screen is installed before running fireplace.

NOTICE: During initial operation of new fireplace, burning logs will give off a paper-burning smell. Open window to vent smell. Operate fireplace on HI position to burn off odor. This will only last a few hours.

⚠ WARNING: Burner will come on automatically within one minute when control valve is in the ON position after the pilot is lit.

1. STOP! Read the safety information, above.
2. Make sure equipment shutoff valve is fully open.
3. Press in and turn control knob clockwise ↷ to the OFF position (see Figure 31).
4. Wait five (5) minutes to clear out any gas. Then smell for gas, including near the floor. If you smell gas, STOP! Follow "B" in the safety information, above. If you don't smell gas, go to the next step.

OPERATION *Continued*

REMOTE-READY MODELS

TO TURN OFF GAS TO APPLIANCE

Shutting Off Fireplace

1. Turn control knob clockwise  to the OFF position.
2. If Using Optional Hand-Held Remote: Set selector switch in the OFF position to prevent draining battery.
3. Close equipment shutoff valve (see Figure 16, page 13).

⚠ WARNING: Make sure remote sensor selector switch is in the OFF position when you are away from home for long periods of time.

MANUAL LIGHTING PROCEDURE

1. Follow steps 1 through 5 under Lighting Instructions, page 18.
2. Press control knob and light pilot with match.
3. Keep control knob pressed in for 30 seconds after lighting pilot. After 30 seconds, release control knob. Now follow steps 8 and 9 under Lighting Instructions, page 18.

OPTIONAL HAND-HELD REMOTE OPERATION

Note: All remote control accessories must be purchased separately (see Accessories, page 32). Follow instructions included with the remote control.

NOTICE: You must light the pilot before using the hand-held remote control unit. See Lighting Instructions on page 18.

After lighting, let pilot flame burn for about one minute. Turn control knob to ON position. Adjust flame adjustment knob anywhere between HI and LO. Slide the selector switch to the REMOTE position (see Figure 32). **Note:** The burner may light if hand-held remote was on when selector switch was last turned off. You can now turn the burner on and off with the hand-held remote control unit.

IMPORTANT: Do not leave the selector switch in the REMOTE or ON position when the pilot is not lit. This will drain the battery.

OPTIONAL GWMT1 (F0240) WALL MOUNTED THERMOSTAT

Set the temperature adjustment on wall thermostat to the desired setting. The thermostat has been electronically calibrated at the factory and requires no adjustment or leveling.

Upon installation, the thermostat must be allowed to stabilize at room temperature for a minimum of 30 minutes for proper operation. See installation instructions on pages 14 and 15.

OPTIONAL GWMS2 (F0245) WALL MOUNTED SWITCH

This wall switch works just like the conventional light switch. Flip switch up for on and down for off.

Note: Make sure that this switch is not in a position to be mistaken for a light switch. This may result in the fireplace being inadvertently turned on without the proper precautions being taken. See installation instructions on page 15.

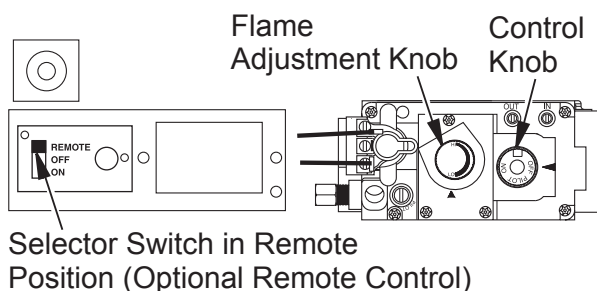

Figure 32 - Setting the Selector Switch, Control Knob and Flame Adjustment Knob for Remote Operation

INSPECTING BURNERS

Check pilot flame pattern and burner flame patterns often.

PILOT FLAME PATTERN

Figure 33 shows a correct pilot flame pattern. Figure 34 shows an incorrect pilot flame pattern. The incorrect pilot flame is not touching the thermocouple. This will cause the thermocouple to cool. When the thermocouple cools, the fireplace will shut down.

If pilot flame pattern is incorrect, as shown in Figure 34

- turn fireplace off (see [To Turn Off Gas to Appliance](#), page 17 for Thermostat-Controlled Models or page 19 for Remote-Ready Models)
- see [Troubleshooting](#), page 22

Note: The pilot flame on natural gas units will have a slight curve, but flame should be blue and have no yellow or orange color.

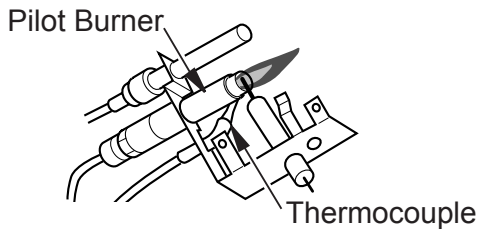

Figure 33 - Correct Pilot Flame Pattern (Propane/LP Remote-Ready Shown)

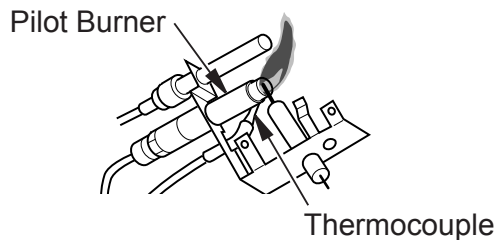

Figure 34 - Incorrect Pilot Flame Pattern (Propane/LP Remote-Ready Shown)

BURNER FLAME PATTERN

Figure 35 shows a correct burner flame pattern. Figure 36 shows an incorrect burner flame pattern. The incorrect burner flame pattern shows sporadic, irregular flame tipping. The flame should not be dark or have an orange/reddish tinge.

Note: When using the fireplace the first time, the flame will be orange for approximately one hour until the log cures.

If burner flame pattern is incorrect, as shown in Figure 36

- turn fireplace off (see [To Turn Off Gas to Appliance](#), page 17 for Thermostat-Controlled Models or page 19 for Remote-Ready Models)
- see [Troubleshooting](#), page 22



Figure 35 - Correct Burner Flame Pattern

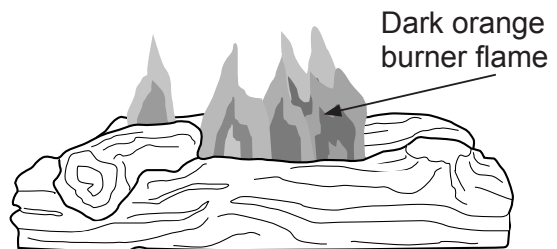

Figure 36 - Incorrect Burner Flame Pattern

CLEANING AND MAINTENANCE

⚠ WARNING: Turn off fireplace and let cool before cleaning.

⚠ CAUTION: You must keep control areas, burner and circulating air passageways of fireplace clean. Inspect these areas of fireplace before each use. Have fireplace inspected yearly by a qualified service person. Fireplace may need more frequent cleaning due to excessive lint from carpeting, pet hair, bedding material, etc.

⚠ WARNING: Failure to keep the primary air opening(s) of the burner(s) clean may result in sooting and property damage.

Clean the pilot assembly also. A yellow tip on the pilot flame indicates dust and dirt in the pilot assembly. There is a small pilot air inlet hole about 2" from where the pilot flame comes out of the pilot assembly (see Figures 38 or 39 depending on model). With the unit off, lightly blow air through the air inlet hole. You may blow through a drinking straw if compressed air is not available.

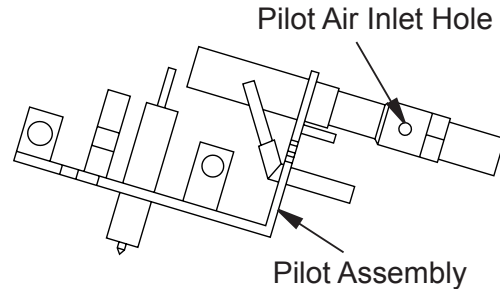

Figure 38 - Pilot Inlet Air Hole (Propane/LP Gas)

BURNER INJECTOR HOLDER AND PILOT AIR INLET HOLE

The primary air inlet holes allow the proper amount of air to mix with the gas. This provides a clean burning flame. Keep these holes clear of dust, dirt, lint and pet hair. Clean these air inlet holes prior to each heating season. Blocked air holes will create soot. We recommend that you clean the unit every three months during operation and have fireplace inspected yearly by a qualified service person.

We also recommend that you keep the burner tube and pilot assembly clean and free of dust and dirt. To clean these parts we recommend using compressed air no greater than 30 PSI. Your local computer store, hardware store or home center may carry compressed air in a can. If using compressed air in a can, please follow the directions on the can. If you don't follow directions on the can, you could damage the pilot assembly.

1. Shut off unit including pilot. Allow unit to cool for at least 30 minutes.
2. Inspect burner, pilot and primary air inlet holes on injector holder for dust and dirt (see Figure 37).
3. Blow air through the ports/slots and holes in the burner.
4. Check the injector holder located at the end of the burner tube again. Remove any large particles of dust, dirt, lint or pet hair with a soft cloth or vacuum cleaner nozzle.
5. Blow air into the primary air holes on the injector holder.
6. In case any large clumps of dust have now been pushed into the burner repeat steps 3 and 4.

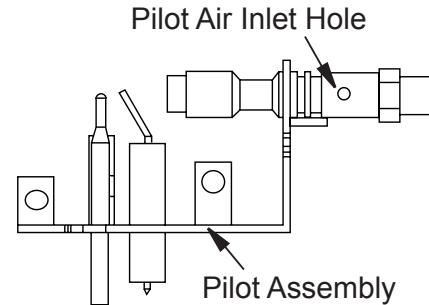

Figure 39 - Pilot Inlet Air Hole (Natural Gas)

LOG SET

- If you remove one-piece log set for cleaning, refer to page 18, for placement instructions.
- Replace log set if broken or chipped (dime-sized or larger).

CABINET

Air Passageways

Use a vacuum cleaner or pressurized air to clean.

Exterior

Use a soft cloth dampened with a mild soap and water mixture. Wipe the cabinet to remove dust.

WIRING DIAGRAM

(Remote-Ready Models Only)

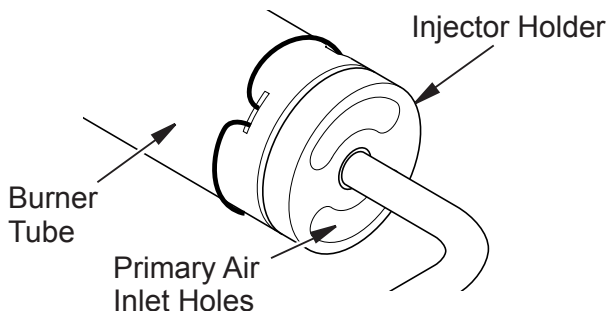
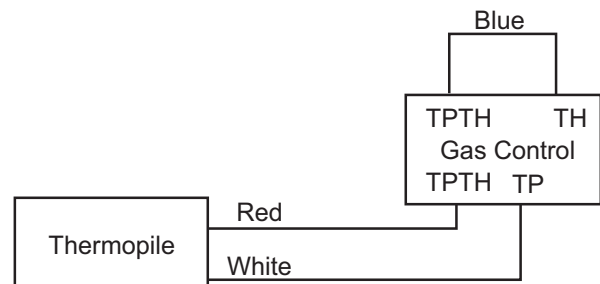

Figure 37 - Injector Holder On Outlet Burner Tube



TROUBLESHOOTING

⚠ WARNING: Turn off and unplug fireplace and let cool before servicing. Only a qualified service person should service and repair fireplace.

⚠ CAUTION: Never use a wire, needle or similar object to clean ODS/pilot. This can damage ODS/pilot unit.

Note: All troubleshooting items are listed in order of operation.

OBSERVED PROBLEM	POSSIBLE CAUSE	REMEDY
When igniter button is pressed, there is no spark at ODS/pilot	<ol style="list-style-type: none"> 1. Igniter electrode not connected to igniter cable 2. Igniter cable pinched or wet 3. Broken igniter cable 4. Bad piezo igniter 5. Igniter electrode positioned wrong 6. Igniter electrode broken 	<ol style="list-style-type: none"> 1. Reconnect igniter cable 2. Free igniter cable if pinched by any metal or tubing. Keep igniter cable dry 3. Replace igniter cable 4. Replace piezo igniter 5. Replace pilot assembly 6. Replace pilot assembly
When igniter button is pressed, there is spark at ODS/pilot but no ignition	<ol style="list-style-type: none"> 1. Gas supply turned off or equipment shutoff valve closed 2. Control knob not in PILOT position 3. Control knob not pressed in while in PILOT position 4. Air in gas lines when installed 5. Depleted gas supply (propane/LP only) 6. ODS/pilot is clogged 7. Gas regulator setting is not correct 	<ol style="list-style-type: none"> 1. Turn on gas supply or open equipment shutoff valve 2. Turn control knob to PILOT position 3. Press in control knob while in PILOT position 4. Continue holding down control knob. Repeat igniting operation until air is removed 5. Contact local propane/LP gas company 6. Clean ODS/pilot (see Cleaning and Maintenance, page 21) or replace ODS/pilot assembly 7. Replace gas regulator
ODS/pilot lights but flame goes out when control knob is released	<ol style="list-style-type: none"> 1. Control knob not fully pressed in 2. Control knob not pressed in long enough 3. Safety interlock system has been triggered 4. Equipment shutoff valve not fully open 5. Pilot flame not touching thermocouple, which allows thermocouple to cool, causing pilot flame to go out. This problem could be caused by one or both of the following: <ol style="list-style-type: none"> A) Low gas pressure B) Dirty or partially clogged ODS/pilot 6. Thermocouple connection loose at control valve 7. Thermocouple damaged 8. Control valve damaged 	<ol style="list-style-type: none"> 1. Press in control knob fully 2. After ODS/pilot lights, keep control knob pressed in 30 seconds 3. Wait one minute for safety interlock system to reset. Repeat ignition operation 4. Fully open equipment shutoff valve 5. <ol style="list-style-type: none"> A) Contact local natural or propane/LP gas company B) Clean ODS/pilot (see Cleaning and Maintenance, page 21) or replace ODS/pilot assembly 6. Hand tighten until snug, then tighten 1/4 turn more 7. Replace pilot assembly 8. Replace control valve

TROUBLESHOOTING *Continued*

OBSERVED PROBLEM	POSSIBLE CAUSE	REMEDY
Burner does not light after ODS/pilot is lit	<ol style="list-style-type: none"> 1. Inlet gas pressure is too low 2. Burner orifice is clogged 3. Thermopile leads disconnected or improperly connected (Remote-Ready Models Only) 4. Burners will not come on in remote position (Remote-Ready Models Only) 	<ol style="list-style-type: none"> 1. Contact local natural or propane/LP gas company 2. Clean burner (see Cleaning and Maintenance, page 21) or replace burner orifice 3. Reconnect leads (see Wiring Diagram, page 21) 4. Replace battery in transmitter and receiver
Delayed ignition of burner	<ol style="list-style-type: none"> 1. Manifold pressure is too low 2. Burner orifice is clogged 	<ol style="list-style-type: none"> 1. Contact local natural or propane/LP gas company 2. Clean burner (see Cleaning and Maintenance, page 21) or replace burner orifice
Burner backfiring during combustion	<ol style="list-style-type: none"> 1. Burner orifice is clogged or damaged 2. Damaged burner 3. Gas regulator defective 4. Inlet gas pressure is too low 	<ol style="list-style-type: none"> 1. Clean burner (see Cleaning and Maintenance, page 21) or replace burner orifice 2. Replace damaged burner 3. Replace gas regulator 4. Contact local natural or propane/LP gas company
Slight smoke or odor during initial operation	<ol style="list-style-type: none"> 1. Residues from manufacturing processes and log curing 2. Not enough air 3. Gas regulator defective 	<ol style="list-style-type: none"> 1. Problem will stop after a few hours of operation 2. Check burner for dirt and debris. If found, clean burner (see Cleaning and Maintenance, page 21) 3. Replace gas regulator
Fireplace produces a whistling noise when burner is lit	<ol style="list-style-type: none"> 1. Turning control knob to HI position when burner is cold 2. Air in gas line 3. Air passageways on fireplace blocked 4. Dirty or partially clogged burner orifice 	<ol style="list-style-type: none"> 1. Turn control knob to LO position and let warm up for a minute 2. Operate burner until air is removed from line. Have gas line checked by local natural gas company 3. Observe minimum installation clearances (see page 8) 4. Clean burner (see Cleaning and Maintenance, page 21) or replace burner orifice
White powder residue forming within burner box or on adjacent walls or furniture	<ol style="list-style-type: none"> 1. When heated, vapors from furniture polish, wax, carpet cleaners, etc. may turn into white powder residue 	<ol style="list-style-type: none"> 1. Turn fireplace off when using furniture polish, wax, carpet cleaners or similar products
Moisture/condensation noticed on windows	<ol style="list-style-type: none"> 1. Not enough combustion/ventilation air 	<ol style="list-style-type: none"> 1. Refer to Air for Combustion and Ventilation requirements (page 6)
Remote does not function (Remote-Ready Models Only)	<ol style="list-style-type: none"> 1. Battery is not installed. Battery power is low 	<ol style="list-style-type: none"> 1. Replace 9-volt batteries in receiver and remote control
Fireplace produces a clicking/ticking noise just after burners are lit or shut off	<ol style="list-style-type: none"> 1. Metal expanding while heating or contracting while cooling 	<ol style="list-style-type: none"> 1. This is normal with most fireplaces. If noise is excessive, contact qualified service person

TROUBLESHOOTING *Continued*

- ⚠ WARNING: If you smell gas**
- Shut off gas supply.
 - Do not try to light any appliance.
 - Do not touch any electrical switch; do not use any phone in your building.
 - Immediately call your gas supplier from a neighbor's phone. Follow the gas supplier's instructions.
 - If you cannot reach your gas supplier, call the fire department.

IMPORTANT: Operating fireplace where impurities in air exist may create odors. Cleaning supplies, paint, paint remover, cigarette smoke, cements and glues, new carpet or textiles, etc., create fumes. These fumes may mix with combustion air and create odors. These odors will disappear over time.

OBSERVED PROBLEM	POSSIBLE CAUSE	REMEDY
Fireplace produces unwanted odors	<ol style="list-style-type: none"> 1. Fireplace burning vapors from paint, hair spray, glues, cleaners, chemicals, new carpet, etc. (See IMPORTANT statement above) 2. Low fuel supply (propane/LP only) 3. Gas leak. See Warning statement at top of page 	<ol style="list-style-type: none"> 1. Open window to ventilate room. Stop using odor causing products while fireplace is running 2. Refill supply tank (propane/LP only) 3. Locate and correct all leaks (see Checking Gas Connections, page 13)
Fireplace shuts off in use (ODS operates)	<ol style="list-style-type: none"> 1. Not enough fresh air is available 2. Low line pressure 3. ODS/pilot is partially clogged 	<ol style="list-style-type: none"> 1. Open window and/or door for ventilation 2. Contact local natural or propane/LP gas company 3. Clean ODS/pilot (see Cleaning and Maintenance, page 21)
Gas odor even when control knob is in OFF position	<ol style="list-style-type: none"> 1. Gas leak. See Warning statement at top of page 2. Control valve defective 	<ol style="list-style-type: none"> 1. Locate and correct all leaks (see Checking Gas Connections, page 13) 2. Replace control valve
Gas odor during combustion	<ol style="list-style-type: none"> 1. Foreign matter between control valve and burner 2. Gas leak. See Warning statement at top of page 	<ol style="list-style-type: none"> 1. Take apart gas tubing and remove foreign matter 2. Locate and correct all leaks (see Checking Gas Connections, page 13)

SPECIFICATIONS

THERMOSTAT MODELS

Brookhill26ZTP

- Rating (Variable): 17,000/26,000 Btu/Hr
- Type Gas: Propane/LP
- Ignition: Piezo
- Manifold Pressure: 8" W.C.
- Inlet Gas Pressure (in. of water):
Max - 14" W.C., Min* - 11" W.C.

Brookhill26ZTN

- Rating (Variable): 17,000/26,000 Btu/Hr
- Type Gas: Natural
- Ignition: Piezo
- Manifold Pressure: 3.5" W.C.
- Inlet Gas Pressure (in. of water):
Max - 10.5" W.C., Min* - 5" W.C.

* For purpose of input adjustment

REMOTE-READY MODELS

Concord26ZMP

- Rating (Variable): 17,000/26,000 Btu/Hr
- Type Gas: Propane/LP
- Ignition: Piezo
- Manifold Pressure: 8" W.C.
- Inlet Gas Pressure (in. of water):
Max - 14" W.C., Min* - 11" W.C.

Concord26ZMN

- Rating (Variable): 17,000/26,000 Btu/Hr
- Type Gas: Natural
- Ignition: Piezo
- Manifold Pressure: 3.5" W.C.
- Inlet Gas Pressure (in. of water):
Max - 10.5" W.C., Min* - 5" W.C.

* For purpose of input adjustment

SERVICE HINTS

When Gas Pressure Is Too Low

- pilot will not stay lit
- burner will have delayed ignition
- fireplace will not produce specified heat
- for propane/LP unit, propane/LP gas supply may be low

You may feel your gas pressure is too low. If so, contact your local gas supplier.

TECHNICAL SERVICE

You may have further questions about installation, operation, or troubleshooting. Please contact your IHP dealer for any questions or concerns. When contacting your dealer please have your model and serial numbers of your fireplace ready. You can also visit our web site at Comfortflame.US.com.

REPLACEMENT PARTS

See Pages 26 to 31 for a complete replacement parts list. Use only parts supplied from the manufacturer.

Normally, all parts should be ordered through your IHP distributor or dealer. Parts will be shipped at prevailing prices at time of order.

When ordering repair parts, always give the following information:

1. The model number of the fireplace.
2. The serial number of the fireplace.
3. The part number.
4. The description of the part.
5. The quantity required.
6. The installation date of the fireplace.

If you encounter any problems or have any questions concerning the installation or application of this fireplace, please contact your dealer.

IHP

1508 Elm Hill Pike, Suite 108

Nashville, TN 37210

Visit us at Comfortflame.US.com

PARTS

FIREBOX MODELS: Brookhill26ZTN, Brookhill26ZTP, Concord26ZMN, Concord26ZMP

CATALOG NO.	MODEL
F2502	Brookhill26ZTN
F2503	Brookhill26ZTP
F2504	Concord26ZMN
F2505	Concord26ZMP

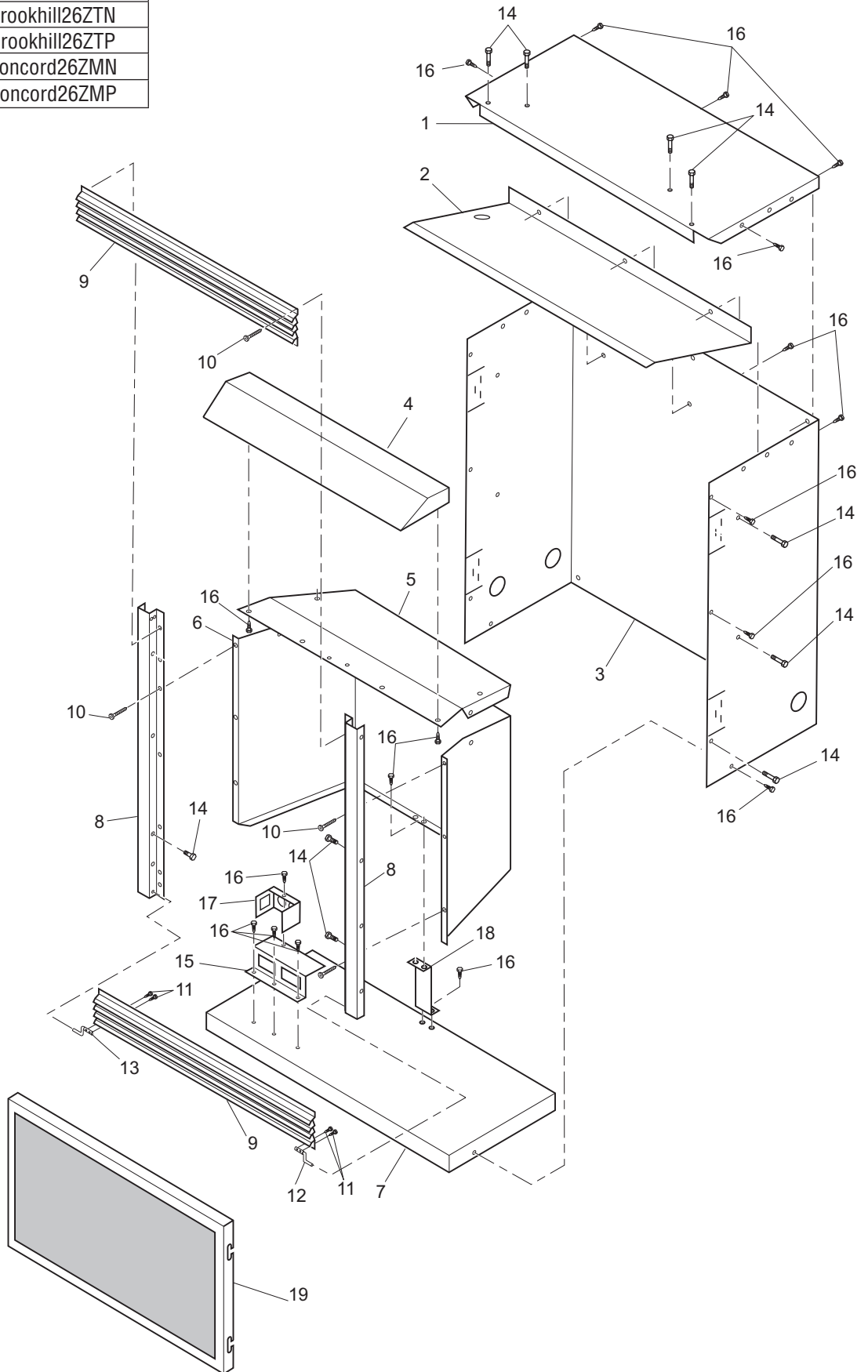

PARTS

FIREBOX MODELS: Brookhill26ZTN, Brookhill26ZTP, Concord26ZMN, Concord26ZMP

This list contains replaceable parts used in your fireplace. When ordering parts, follow the instructions listed under [Replacement Parts](#) on page 25 of this manual.

⚠ WARNING: Contact an IHP dealer to obtain any of these parts. Never use substitute materials not approved by IHP. Use of non-approved parts can result in poor performance and safety hazards.

KEY NO.	CATALOG NO.	DESCRIPTION	QTY.
1	**	Outer Casing Top	1
2	**	Baffle	1
3	**	Outer Casing	1
4	J3863	Firebox Hood	1
5	**	Firebox Top	1
6	**	Firebox Wrapper	1
7	**	Outer Base	1
8	J8053	Front Left and Right Sides	2
9	J3790	Extruded Louver	2
10	J3575	Screw, PPH AB 6-20 x 0.38	5
11	J1953	Screw, SLTD HWH TPG 6-32 x 0.38	4
12	J3869	Right Pin Hinge	1
13	J3870	Left Pin Hinge	1
14	J3629	Screw, HWH SHLDR AB 10 x 0.63	14
15	111038-02	Remote/Blower Bracket	1
16	J1955	Screw, HWH AB 10-16 x 0.38	35
17	111633-01	Box Cover	1
18	J4522	Support Bracket	1
19	J3802	Screen Frame	1

** Not a field replacement part

PARTS

THERMOSTAT MODELS: Brookhill26ZTN, Brookhill26ZTP

CATALOG NO.	MODEL
F2502	Brookhill26ZTN
F2503	Brookhill26ZTP

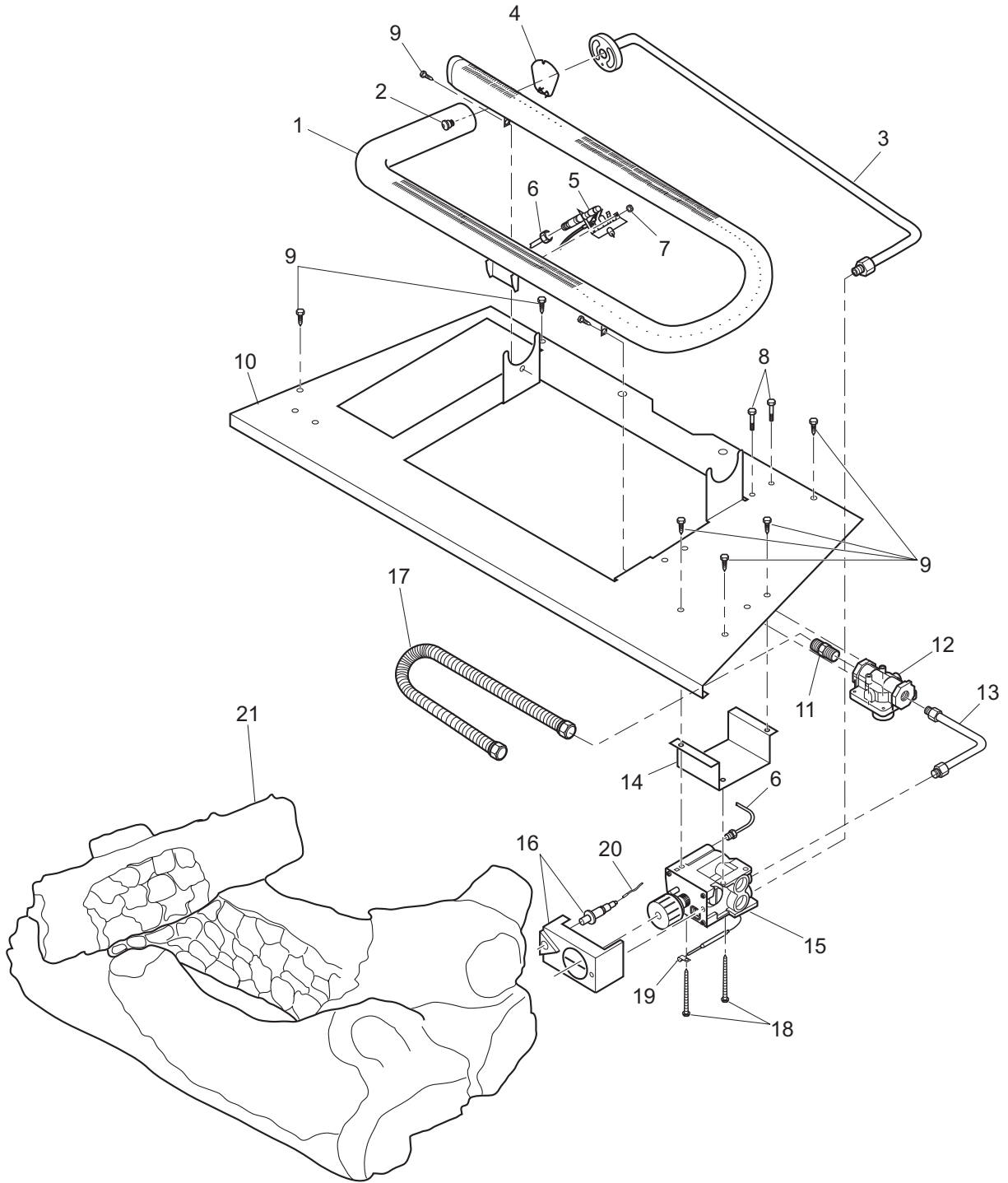

PARTS

THERMOSTAT MODELS: Brookhill26ZTN, Brookhill26ZTP

This list contains replaceable parts used in your fireplace. When ordering parts, follow the instructions listed under [Replacement Parts](#) on page 25 of this manual.

⚠ WARNING: Contact an IHP dealer to obtain any of these parts. Never use substitute materials not approved by IHP. Use of non-approved parts can result in poor performance and safety hazards.

KEY NO.	CATALOG NO.	DESCRIPTION	Brookhill26ZTP	Brookhill26ZTN	QTY
			F2503	F2502	
1	J4502	Dual Burner	•	•	1
2	J3614	Injector	•		1
	J3616	Injector		•	1
3	J3875	Outlet Tube	•	•	1
4	J4514	Burner Retainer Spring	•	•	1
5	J4033	ODS Pilot	•		1
	J4032	ODS Pilot		•	1
6	J3635	Pilot Tube	•	•	1
7	J3558	ODS Nut	•	•	2
8	J1958	Screw, HWH AB 8-18 x 0.38	•	•	2
9	J1955	Screw, HWH AB 10-16 x 0.38	•	•	10
10	**	Chamber Floor	•	•	1
11	J3550	Male Fitting	•	•	1
12	J3595	Gas Regulator	•		1
	J3596	Gas Regulator		•	1
13	J4219	Inlet Tube	•	•	1
14	J8054	Control Bracket	•	•	1
15	J3585	Thermostat Gas Valve	•		1
	J3584	Thermostat Gas Valve		•	1
16	J3714	Valve Cover with Piezo	•	•	1
17	J3726	Flexible Connector	•	•	1
18	J3625	Screw, HWH AB 10-16 x 2.50	•	•	2
19	J3593	Thermobulb Clip	•	•	1
20	J3569	Igniter Cable	•	•	1
21	J4925	Log Set	•	•	1
PARTS AVAILABLE — NOT SHOWN					
	J7197	Brass Flare Adapter Fitting	•	•	1
	J3813	Hardware Pack	•	•	1
	J3658	Warning Plate	•	•	1
	J3686	Lighting Instruction Plate	•	•	1

** Not a field replacement part

PARTS

REMOTE-READY MODELS: Concord26ZMN, Concord26ZMP

CATALOG NO.	MODEL
F2504	Concord26ZMN
F2505	Concord26ZMP

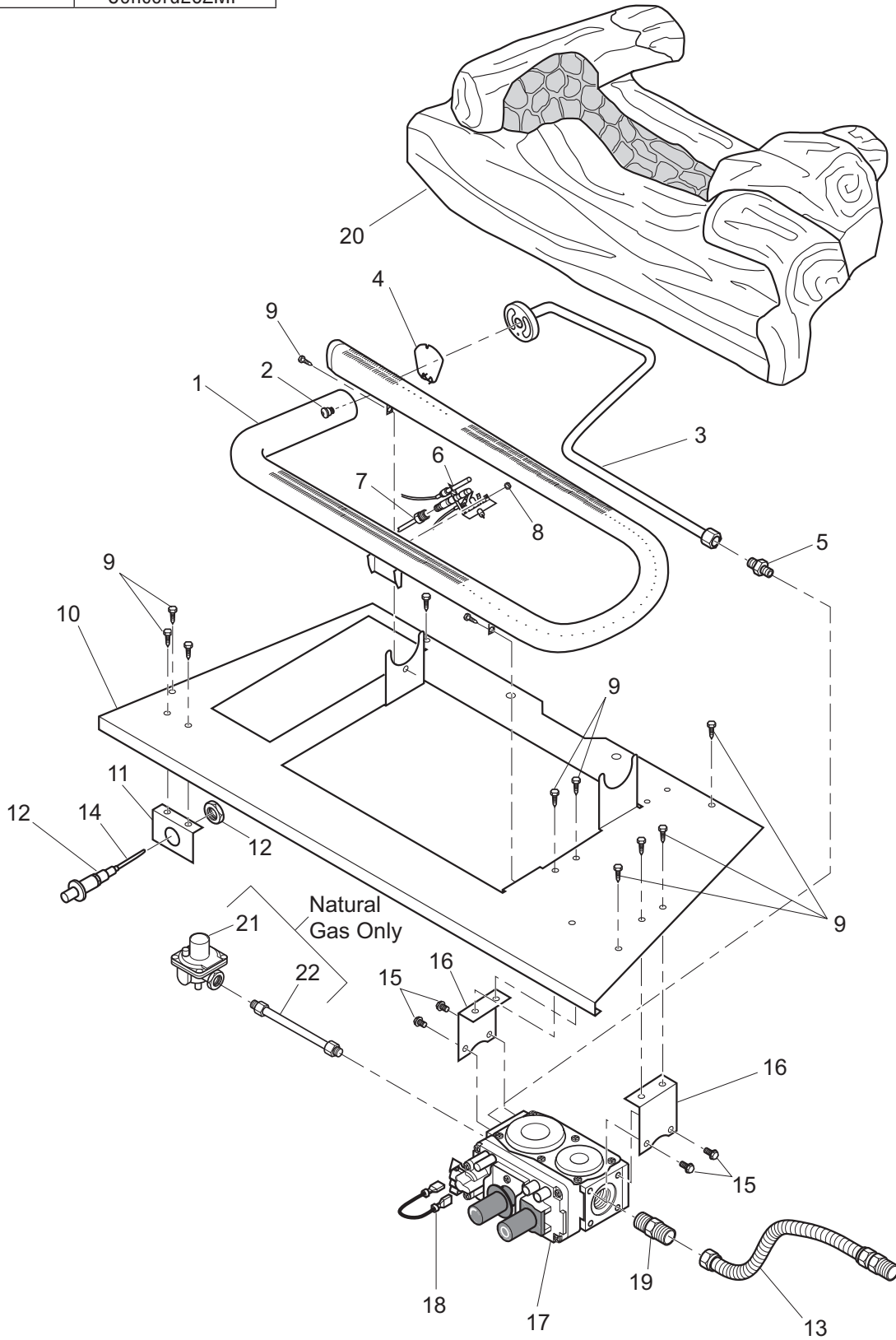

PARTS

REMOTE-READY MODELS: Concord26ZMN, Concord26ZMP

This list contains replaceable parts used in your fireplace. When ordering parts, follow the instructions listed under [Replacement Parts](#) on page 29 of this manual.



⚠ WARNING: Contact an IHP dealer to obtain any of these parts. Never use substitute materials not approved by IHP. Use of non-approved parts can result in poor performance and safety hazards.

KEY NO.	CATALOG NO.	DESCRIPTION	Concord26ZMP	Concord26ZMN	QTY.
			F2505	F2504	
1	J4502	Dual Burner	•	•	1
2	J3614	Injector	•		1
	J3616	Injector		•	1
3	J3806	Outlet Tube	•		1
	J4520	Outlet Tube		•	1
4	J4514	Burner Retainer Spring	•	•	1
5	J3550	Male Fitting	•	•	1
6	J3830	ODS Pilot	•		1
	J3831	ODS Pilot		•	1
7	J3635	Pilot Tube	•		1
	J3637	Pilot Tube		•	1
8	J3558	ODS Nut	•	•	2
9	J1955	Screw, HWH AB 10-16 x 0.38	•	•	10
10	**	Chamber Floor	•	•	1
11	J8055	Piezo Bracket	•	•	1
12	J3746	Piezo Igniter with Palnut Fastener	•	•	1
13	J3725	Flexible Connector	•	•	1
14	J3569	Igniter Cable	•	•	1
15	J1961	Screw, MX SLT WSR 10-32 x 3/8	•	•	4
16	J4516	Remote Valve Bracket	•	•	2
17	J3837	Gas Valve	•		1
	J3836	Gas Valve		•	1
18	J3720	ASM High Temp Wire			1
19	J3530	Male Fitting	•	•	1
20	J4925	Log Set	•	•	1
21	J3654	Pilot Regulator		•	1
22	J3639	Pilot Tube		•	1
PARTS AVAILABLE — NOT SHOWN					
	J7197	Brass Flare Adapter Fitting	•	•	1
	J3813	Hardware Pack	•	•	1
	J3658	Warning Plate	•	•	1
	J3846	Lighting Instruction Plate	•	•	1

** Not a field replacement part

ACCESSORIES

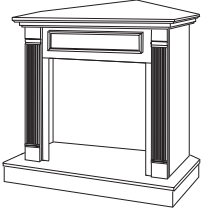
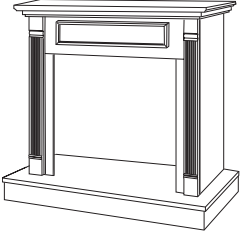
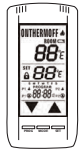
Purchase these fireplace accessories from your local dealer. If they can not supply these accessories, contact IHP at Comfortflame.US.com for referral information.

CAT NO.	MODEL	DESCRIPTION	
CORNER CABINET MANTEL WITH FULL HEARTH BASE			
For all models. Space saving mantel and hearth base corner design. Complete assembly instructions included.			
F1148	C26GO	26" Corner Cabinet Mantle, Georgian Style, Light Oak Stain	
F1139	C26TO	26" Corner Cabinet Mantle, Traditional Style, Light Oak Stain	
F1809	C26TU	26" Corner Cabinet Mantle, Traditional Style, Unfinished	
CABINET MANTEL AND FULL HEARTH BASE			
For all models. Mantel features clean, classic lines. Complete assembly instructions included.			
F1138	W26TO	26" Wall Cabinet Mantle, Traditional Style, Light Oak Stain	
F1808	W26TU	26" Wall Cabinet Mantle, Traditional Style, Unfinished	
WALL-MOUNT THERMOSTAT SWITCH KIT			<p style="text-align: center;">(Not Shown)</p>
For all Remote-Ready Models. The desired comfort setting can be selected on the wall thermostat and the fireplace will automatically cycle from pilot to the heat setting selected.			
F2040	GWMT1	Thermostat Wall Mount kit	
WALL-MOUNT ON/OFF SWITCH			<p style="text-align: center;">(Not Shown)</p>
For all Remote-Ready Models. Allows the fireplace to be turned on and off with a wall switch.			
F0245	GWMS2	Switch Wall Mount Kit	
RECEIVER AND HAND-HELD TOUCH-SCREEN THERMOSTAT REMOTE CONTROL KIT			
For all models. Allows gas log heater to be operated in a manually, thermostatically, or programmed controlled mode.			
F1079	TSRC	Receiver and Touch Screen Remote Control Kit	
RECEIVER AND HAND-HELD THERMOSTAT REMOTE CONTROL KIT			
For all Remote-Ready Models. Allows the fireplace to be operated in a manually or thermostatically controlled mode. You can turn the fireplace on and off without ever leaving the comfort of your easy chair. A wall-mount docking station is included.			
F1078	TRC	Thermostatic On/Off Remote Control Kit	
RECEIVER AND HAND-HELD REMOTE CONTROL KIT			
For all Remote-Ready Models. Allows the fireplace to be turned on and off by using a hand-held remote control. A wall-mount docking station is included.			
F2236	RCKIT4001	Standard On/Off Remote Control Kit	

ACCESSORIES *Continued*

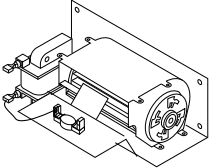
PERIMETER TRIM KIT			(Not shown)
For all models. Optional three-sided perimeter trim kit for custom and recessed installations (when unit is on the floor). Provides a finished appearance by covering rough edges of wall opening. Black trim included with all mantels.			
F1816	GAB6094	KIT, BLACK TRIM 26" 3PC	
J1275	GAP6094	KIT, PLATINUM TRIM 26" 3PC	
EXTRUDED LOUVER KIT			(Not shown)
For all models, Optional extruded louver Kit contains 2 louvers			
J1276	GAP9092	LOUVER, EXTRUDED 26" PLATINUM	
THERMOSTAT-CONTROLLED BLOWER KIT			
For all models. Provides better heat distribution. Makes fireplace more efficient. Automatically turns off and on as needed.			
J1281	GA3450TA	KIT, T-STAT BLOWER	

Innovative Hearth Products Comfort Flame™ Brand Gas Fireplace and Insert 20 Year Limited Warranty

THE WARRANTY

Innovative Hearth Products ("IHP") 20 Year Limited Warranty warrants your Comfort Flame™ Brand gas fireplace or insert ("Product") to be free from defects in materials and workmanship at the time of manufacture. The Product body and firebox carry the 20 Year Limited Warranty. Ceramic glass carries the 20 Year Limited Warranty against thermal breakage only. After installation, if covered components manufactured by IHP are found to be defective in materials or workmanship during the 20 Year Limited Warranty period and while the Product remains at the site of the original installation, IHP will, at its option, repair or replace the covered components. If repair or replacement is not commercially practical, IHP will, at its option, refund the purchase price or wholesale price of the IHP product, whichever is applicable. IHP will also pay IHP prevailing labor rates, as determined in its sole discretion, incurred in repairing or replacing such components for up to five years. THERE ARE EXCLUSIONS AND LIMITATIONS to this 20 Year Limited Warranty as described herein.

COVERAGE COMMENCEMENT DATE

Warranty coverage begins on the date of purchase. In the case of new home construction, warranty coverage begins on the date of first occupancy of the dwelling or six months after the sale of the Product by an independent IHP dealer/distributor, whichever occurs earlier. The warranty shall commence no later than 24 months following the date of product shipment from IHP, regardless of the installation or occupancy date.

EXCLUSIONS AND LIMITATIONS

This 20 Year Limited Warranty applies only if the Product is installed in the United States or Canada and only if operated and maintained in accordance with the printed instructions accompanying the Product and in compliance with all applicable installation and building codes and good trade practices.

This warranty is non-transferable and extends to the original owner only. The Product must be purchased through a listed supplier of IHP and proof of purchase must be provided. The Product body and firebox carry the 20 Year Limited Warranty from the date of installation. Vent components, trim components and paint are excluded from this 20 Year Limited Warranty. The following do not carry the 20 Year Limited Warranty but are warranted as follows:

- Burner** – Repair or replacement for one year from the date of installation
- Gas components** – Repair or replacement for one year from the date of installation
- Gaskets** – Repair or replacement for one year from the date of installation
- Gold & nickel plating** – Replacement for two years from date of installation. Excludes tarnishing
- Logs** – Replacement for one year from the date of installation against thermal breakage only
- Optional blowers & remote controls** – Repair or replacement for one year from the date of installation
- Optional glass doors** – Repair or replacement for 90 days from the date of installation
- Tempered glass** – Replacement for one year from the date of installation
- Labor coverage** – Prevailing IHP labor rates apply for the warranty period of the component

Parts not otherwise listed carry a 90 day warranty from the date of installation.

Whenever practicable, IHP will provide replacement parts, if available, for a period of 10 years from the last date of manufacture of the Product.

IHP will not be responsible for: (a) damages caused by normal wear and tear, accident, riot, fire, flood or acts of God; (b) damages caused by abuse, negligence, misuse, or unauthorized alteration or repair of the Product affecting its stability or performance (The Product must be subjected to normal use. The Product is designed to burn either natural or propane gas only. Burning conventional fuels such as wood, coal or any other solid fuel will cause damage to the Product, will produce excessive temperatures and could result in a fire hazard.); (c) damages caused by failing to provide proper maintenance and service in accordance with the instructions provided with the Product; (d) damages, repairs or inefficiency resulting from faulty installation or application of the Product.

IHP is not responsible for inadequate fireplace system draft caused by air conditioning and heating systems, mechanical ventilation systems, or general construction conditions which may generate negative pressure in the room in which the appliance is installed. Additionally IHP assumes no responsibility for drafting conditions caused by venting configurations, adjoining trees or buildings, adverse wind conditions or unusual environmental factors and conditions that affect the operation of the unit.

This 20 Year Limited Warranty covers only parts and labor as provided herein. In no case shall IHP be responsible for materials, components or construction, which are not manufactured or supplied by IHP or for the labor necessary to install, repair or remove such materials, components or construction. Additional utility bills incurred due to any malfunction or defect in equipment are not covered by this warranty. All replacement or repair components will be shipped F.O.B. from the nearest stocking IHP factory.

LIMITATION ON LIABILITY

It is expressly agreed and understood that IHP's sole obligation and the purchaser's exclusive remedy under this warranty, under any other warranty, expressed or implied, or in contract, tort or otherwise, shall be limited to replacement, repair, or refund, as specified herein.

In no event shall IHP be liable for any incidental or consequential damages caused by defects in the Product, whether such damage occurs or is discovered before or after repair or replacement, and whether such damage is caused by IHP's negligence. IHP has not made and does not make any representation or warranty of fitness for a particular use or purpose, and there is no implied condition of fitness for a particular use or purpose.

IHP makes no expressed warranties except as stated in this 20 Year Limited Warranty. The duration of any implied warranty is limited to the duration of this expressed warranty.

No one is authorized to change this 20 Year Limited Warranty or to create for IHP any other obligation or liability in connection with the Product. Some states and provinces do not allow the exclusion or limitation of incidental or consequential damages, so the above limitations or exclusions may not apply to you. The provisions of this 20 Year Limited Warranty are in addition to and not a modification of or subtraction from any statutory warranties and other rights and remedies provided by law.

INVESTIGATION OF CLAIMS AGAINST WARRANTY

IHP reserves the right to investigate any and all claims against this 20 Year Limited Warranty and to decide, in its sole discretion, upon the method of settlement.

To receive the benefits and advantages described in this 20 Year Limited Warranty, the appliance must be installed and repaired by a licensed contractor approved by IHP.

Contact IHP at the address provided herein to obtain a listing of approved dealers/distributors. **IHP shall in no event be responsible for any warranty work done by a contractor that is not approved without first obtaining IHP's prior written consent.**

HOW TO REGISTER A CLAIM AGAINST WARRANTY

In order for any claim under this warranty to be valid, you must contact the IHP dealer/distributor from which you purchased the product. If you cannot locate the dealer/distributor, then you must notify IHP in writing. IHP must be notified of the claimed defect in writing within 90 days of the date of failure. Notices should be directed to the IHP Warranty Department at 1508 Elm Hill Pike, Suite 108; Nashville, TN 37210 or visit our website at WWW.COMFORTFLAME.US.COM.

WARRANTY

KEEP THIS WARRANTY

Model Number _____
Serial Number _____
Date Installed _____
Dealer's Name _____
Dealer's Phone Number _____
Keep receipt for warranty verification

Innovative Hearth Products reserves the right to make changes at any time, without notice, in design, materials, specifications, prices and also to discontinue colors, styles and products. Consult your local distributor for fireplace code information.



P900567-00

