



# Installation and Operation Instructions Lexington Lights™ Unvented (Vent-Free) Gas Fireplace System

P/N 900569-00 Rev. F 10/2019



## Models

LexingtonLights43ZEN	LexingtonLights43ZEP
----------------------	----------------------

**INSTALLER:** Leave this manual with the appliance.  
**CONSUMER:** Retain this manual for future reference.

This appliance may be installed in an aftermarket permanently located, manufactured (mobile) home, where not prohibited by local codes. This appliance is only for use with the type of gas indicated on the rating plate. This appliance is not convertible for use with other gases.

This is an unvented gas-fired heater. It uses air (oxygen) from the room in which it is installed. Provisions for adequate combustion and ventilation air must be provided. Refer to Air for Combustion and Ventilation section on page 5 of this manual.

**⚠ WARNING:**  
**FIRE OR EXPLOSION HAZARD**

Failure to follow safety warnings exactly could result in serious injury, death, or property damage.

- Do not store or use gasoline or other flammable vapors and liquids in the vicinity of this or any other appliance.
- **WHAT TO DO IF YOU SMELL GAS:**
  - Do not try to light any appliance.
  - Do not touch any electrical switch; do not use any phone in your building.
  - Leave the building immediately.
  - Immediately call your gas supplier from a neighbor's phone. Follow the gas supplier's instructions.
  - If you cannot reach your gas supplier, call the fire department.
- Installation and service must be performed by a qualified installer, service agency or the gas supplier.

**Thank you for your purchase. We appreciate your business!**

Please carefully read and follow all instructions in this manual. **Pay special attention to all warnings and safety information.**

Following these safety, care, and operation instructions will help ensure many years of dependable and enjoyable service from your fireplace.

**Please read and understand these instructions before installing or operating.**



**NATIONAL FIREPLACE INSTITUTE**  
**NFI**  
**CERTIFIED**  
www.nficertified.org

We recommend that our gas hearth products be installed and serviced by professionals who are certified in the U.S. by the National Fireplace Institute® (NFI) as NFI Gas Specialists.

## TABLE OF CONTENTS

Safety.....	2
Local Codes .....	4
Requirements for the Commonwealth of Massachusetts.....	4
Product Identification.....	4
Product Features.....	5
Air for Combustion and Ventilation .....	5
Installation .....	7
Gas Control Module System .....	15
Remote Control Operation .....	16
Operating Fireplace .....	19
Cleaning and Maintenance .....	20
Inspecting Burners .....	21
Specifications.....	21
Wiring Diagram.....	22
Troubleshooting .....	23
Parts .....	26
Replacement Parts.....	30
Service Hints.....	30
Technical Service .....	30
Accessories.....	30
Warranty .....	31

## SAFETY

### **⚠ WARNING: FIRE, EXPLOSION, AND ASPHYXIATION HAZARD**

**Improper adjustment, alteration, service, maintenance, or installation of this heater or its controls can cause death or serious injury.**

**Read and follow instructions and precautions in User's Information Manual provided with this heater.**

**⚠ WARNING: This is an unvented gas-fired heater. It uses air (oxygen) from the room in which it is installed. Provisions for adequate combustion and ventilation air must be provided. Refer to Air for Combustion and Ventilation section on page 5 of this manual.**

### **⚠ WARNING**

**Never connect this appliance to private (non-utility) gas wells. This Gas is commonly known as wellhead gas and does not have odorants and may have impurities, and variations in BTU content. The use of well-head gas will void the manufacturer's warranty to this appliance.**

**This appliance may be installed in an aftermarket, \* permanently located, manufactured (mobile) home, where not prohibited by local codes.**

**This appliance is only for use with the type of gas indicated on the rating plate. This appliance is not convertible for use with other gases.**

**\* Aftermarket: Completion of sale, not for purpose of resale, from the manufacturer**

**IMPORTANT: Read this owner's manual carefully and completely before trying to assemble, operate or service this heater. Improper use of this heater can cause serious injury or death from burns, fire, explosion, electrical shock and carbon monoxide poisoning.**

**⚠ DANGER: Carbon monoxide poisoning may lead to death!**

**Carbon Monoxide Poisoning:** Early signs of carbon monoxide poisoning resemble the flu, with headaches, dizziness or nausea. If you have these signs, the heater may not be working properly. **Get fresh air at once!** Have heater serviced. Some people are more affected by carbon monoxide than others. These include pregnant women, people with heart or lung disease or anemia, those under the influence of alcohol and those at high altitudes.

**Natural and Propane/LP Gas:** Natural and propane/LP gases are odorless. An odor-making agent is added to the gas. The odor helps you detect a gas leak. However, the odor added to the gas can fade. Gas may be present even though no odor exists.

Make certain you read and understand all warnings. Keep this manual for reference. It is your guide to safe and proper operation of this heater.

## SAFETY *Continued*

**⚠ WARNING: Any change to this heater or its controls can be dangerous.**

**⚠ WARNING: Do not allow fans to blow directly into the fireplace. Avoid any drafts that alter burner flame patterns. Ceiling fans can create drafts that alter burner flame patterns. Altered burner patterns can cause sooting.**

**⚠ WARNING: Do not use a blower insert, heat exchanger insert or other accessory not approved for use with this heater.**

**Due to high temperatures, the appliance should be located out of traffic and away from furniture and draperies.**

**Do not place clothing or other flammable material on or near the appliance. Never place any objects on the heater.**

**Fireplace become very hot when running fireplace. Keep children and adults away from hot surfaces to avoid burns or clothing ignition. Fireplace will remain hot for a time after shutdown. Allow surfaces to cool before touching.**

**Carefully supervise young children when they are in the room with fireplace. When using the remote control, keep selector switch in the OFF position to prevent children from turning on burners with remote.**

**Keep the appliance area clear and free from combustible materials, gasoline and other flammable vapors and liquids.**

1. This appliance is only for use with type of gas indicated on rating plate. This appliance is not convertible for use with other gases.
2. Do not place propane/LP supply tank(s) inside any structure. Locate propane/LP supply tank(s) outdoors (propane/LP only).
3. If you smell gas
  - shut off gas supply
  - do not try to light any appliance
  - do not touch any electrical switch; do not use any phone in your building
  - Leave the building immediately.
  - immediately call your gas supplier from a neighbor's phone. Follow the gas supplier's instructions
  - if you cannot reach your gas supplier, call the fire department
4. This fireplace shall not be installed in a bedroom or bathroom.
5. Do not use this fireplace as a wood-burning fireplace. Use only the logs provided with the fireplace.
6. Do not add extra logs or ornaments such as pine cones, vermicu-

lite, or rock wool. Using these added items can cause sooting. Do not add lava rock around base. Rock and debris could fall into the control area of fireplace.

7. This fireplace is designed to be smokeless. If logs ever appear to smoke, turn off fireplace and call a qualified service person.  
Note: During initial operation, slight smoking could occur due to log curing and fireplace burning manufacturing residues.
8. To prevent the creation of soot, follow the instructions in [Cleaning and Maintenance](#), page 20.
9. Before using furniture polish, wax, carpet cleaner, or similar products, turn heater off. If heated, the vapors from these products may create a white powder residue within burner box or on adjacent walls or furniture.
10. This fireplace needs fresh air ventilation to run properly. This fireplace has an Oxygen Depletion Sensing (ODS) safety shutoff system. The ODS shuts down the fireplace if not enough fresh air is available. See [Air for Combustion and Ventilation](#), page 5. If fireplace keeps shutting off, see [Troubleshooting](#), page 23.
11. Do not run fireplace
  - where flammable liquids or vapors are used or stored.
  - under dusty conditions.
12. Do not use this fireplace to cook food or burn paper or other objects.
13. Do not use fireplace if any part has been under water. Immediately call a qualified service technician to inspect the room fireplace and to replace any part of the control system and any gas control which has been under water.
14. Turn off and unplug fireplace and let cool before servicing. Only a qualified service person should service and repair fireplace.
15. Operating fireplace above elevations of 4,500 feet could cause pilot outage.
16. To prevent performance problems, do not use propane/LP fuel tank of less than 100 lbs. capacity (propane/LP only).
17. Provide adequate clearances around air openings.
18. The screen or any other part removed for servicing must be replaced prior to operating this heater.

## LOCAL CODES

Install and use fireplace with care. Follow all local codes. In the absence of local codes, use the latest edition of The National Fuel Gas Code ANSI Z223.1/NFPA 54\*.

\*Available from:

American National Standards Institute, Inc.  
25 West 43rd Street, 4th floor  
New York, NY 10036

National Fire Protection Association, Inc.  
1 Batterymarch Park  
Quincy, MA 02169-7471

Firebox must be electrically grounded in accordance with the National Electrical Code, ANS/NFPA70 (latest edition).

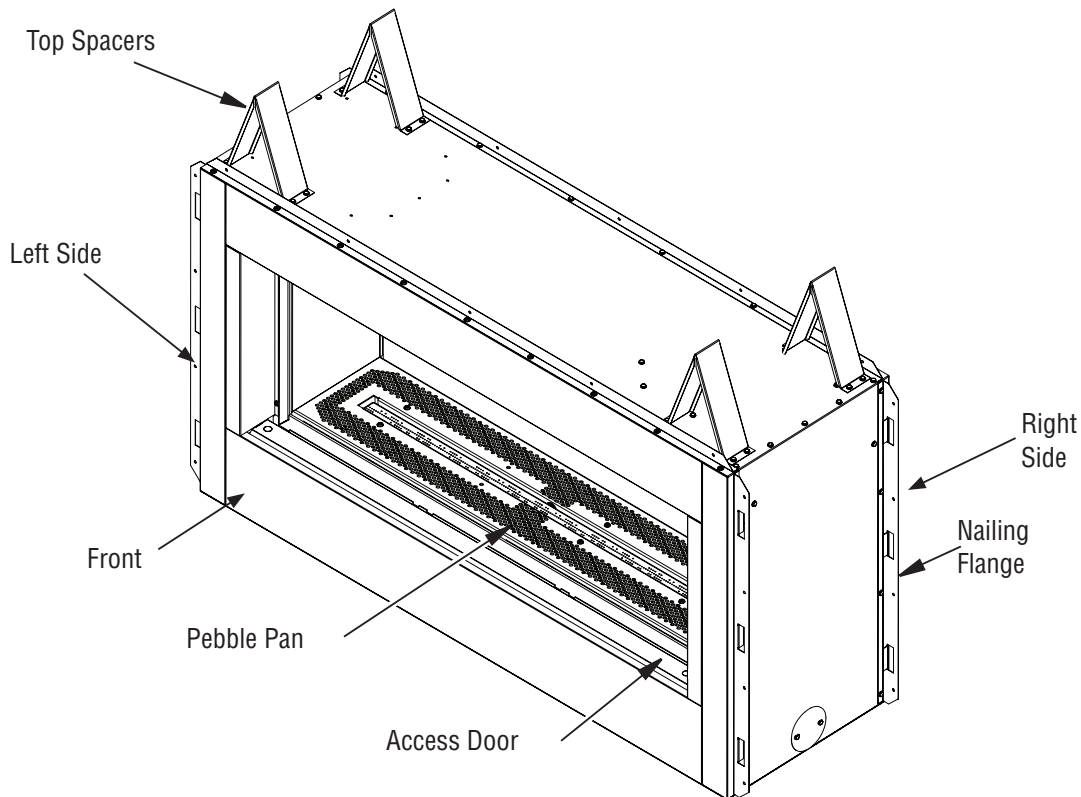
**Listing:** These fireplaces comply with the National Safety Standards and are listed by PFS TECO to ANSI Z21.11.2 as unvented Gas-fired room heaters.

## COMMONWEALTH OF MASSACHUSETTS REQUIREMENTS

These appliances are approved for installation in the US state of Massachusetts if the following additional requirements are met:

- Un-vented Room Heaters shall be installed in accordance with 527 CMR 30.
- Installation and repair must be done by a plumber or gas fitter licensed in the Commonwealth of Massachusetts.
- The flexible gas line connector used shall not exceed 36 inches (92 centimeters) in length.
- The individual manual shut-off must be a T-handle type valve.
- Unvented appliances may NOT be installed in bedrooms or bathrooms.
- A working smoke detector must be installed in the area where vent-free appliances are installed.
- Seller of unvented propane or natural gas-fired supplemental room heaters shall provide to each purchaser a copy of 527 CMR 30 upon sale of the unit.

## PRODUCT IDENTIFICATION



**Figure 1 - Vent Free LexingtonLights43 Fireplace**

## PRODUCT FEATURES

### OPERATION

This vent-free fireplace is clean burning. It requires no outside venting. There is no heat loss out a vent or up a chimney. Heat is generated by both realistic flames. This heater is designed for vent-free operation. It has been tested and approved to ANSI Z21.11.2 standard for unvented heaters. State and local codes in some areas prohibit the use of vent-free heaters.

### SAFETY DEVICE

This fireplace has a pilot with an Oxygen Depletion Sensing (ODS) safety shutoff system. The ODS/pilot is a required feature for vent-free room heaters. The ODS/pilot system shuts off the fireplace if there is not enough fresh air.

## AIR FOR COMBUSTION AND VENTILATION

**⚠ WARNING: This heater shall not be installed in a room or space unless the required volume of indoor combustion air is provided by the method described in the National Fuel Gas Code, ANSI Z223.1/NFPA 54, the International Fuel Gas Code, or applicable local codes. Read the following instructions to insure proper fresh air for this and other fuel-burning appliances in your home.**

Today's homes are built more energy efficient than ever. New materials, increased insulation and new construction methods help reduce heat loss in homes. Home owners weather strip and caulk around windows and doors to keep the cold air out and the warm air in. During heating months, home owners want their homes as airtight as possible.

While it is good to make your home energy efficient, your home needs to breathe. Fresh air must enter your home. All fuel-burning appliances need fresh air for proper combustion and ventilation.

Exhaust fans, fireplaces, clothes dryers and fuel burning appliances draw air from the house to operate. You must provide adequate fresh air for these appliances. This will insure proper venting of vented fuel-burning appliances.

### PROVIDING ADEQUATE VENTILATION

The following are excerpts from National Fuel Gas Code, ANSI Z223.1/NFPA 54, Air for Combustion and Ventilation.

All spaces in homes fall into one of the three following ventilation classifications:

1. Unusually Tight Construction
2. Unconfined Space
3. Confined Space

The information on pages 5 through 6 will help you classify your space and provide adequate ventilation.

### Unusually Tight Construction

The air that leaks around doors and windows may provide enough fresh air for combustion and ventilation. However, in buildings of unusually tight construction, you must provide additional fresh air.

Unusually tight construction is defined as construction where:

- a. walls and ceilings exposed to the outside atmosphere have a continuous water vapor retarder with a rating of one perm ( $6 \times 10^{-11}$  kg per pa-sec- $m^2$ ) or less with openings gasketed or sealed and
- b. weather stripping has been added on openable windows and doors and
- c. caulking or sealants are applied to areas such as joints around window and door frames, between sole plates and floors, between wall-ceiling joints, between wall panels, at penetrations for plumbing, electrical and gas lines and at other openings.

If your home meets all of the three criteria above, you must provide additional fresh air. See [Ventilation Air From Outdoors](#), page 6.

If your home does not meet all of the three criteria above, proceed to [Determining Fresh-Air Flow For Heater Location](#), page 6.

### Confined and Unconfined Space

The National Fuel Gas Code, ANSI Z223.1/NFPA 54 defines a confined space as a space whose volume is less than 50 cubic feet per 1,000 Btu per hour ( $4.8 \text{ m}^3$  per kw) of the aggregate input rating of all appliances installed in that space and an unconfined space as a space whose volume is not less than 50 cubic feet per 1,000 Btu per hour ( $4.8 \text{ m}^3$  per kw) of the aggregate input rating of all appliances installed in that space. Rooms communicating directly with the space in which the appliances are installed\*, through openings not furnished with doors, are considered a part of the unconfined space.

\* Adjoining rooms are communicating only if there are doorless passageways or ventilation grills between them.

## AIR FOR COMBUSTION AND VENTILATION *Continued*

### DETERMINING FRESH-AIR FLOW FOR FIREPLACE LOCATION

Determining if You Have a Confined or Unconfined Space

Use this work sheet to determine if you have a confined or unconfined space.

**Space:** Includes the room in which you will install fireplace plus any adjoining rooms with doorless passageways or ventilation grills between the rooms.

1. Determine the volume of the space (length x width x height).  
 $\text{Length} \times \text{Width} \times \text{Height} = \text{_____ cu. ft. (volume of space)}$   
 Example: Space size 20 ft. (length) x 16 ft. (width) x 8 ft. (ceiling height) = 2,560 cu. ft. (volume of space)

If additional ventilation to adjoining room is supplied with grills or openings, add the volume of these rooms to the total volume of the space.

2. Multiply the space volume by 20 to determine the maximum Btu/Hr the space can support.  
 $\text{_____ (volume of space)} \times 20 = \text{(Maximum Btu/Hr the space can support)}$

Example: 2,560 cu. ft. (volume of space) x 20 = 51,200 (maximum Btu/Hr the space can support)

3. Add the Btu/Hr of all fuel burning appliances in the space.

Vent-free fireplace _____	Btu/Hr
Gas water heater* _____	Btu/Hr
Gas furnace _____	Btu/Hr
Vented gas heater _____	Btu/Hr
Gas fireplace logs _____	Btu/Hr
Other gas appliances*+ _____	Btu/Hr
<b>Total = _____</b>	<b>Btu/Hr</b>

\* Do not include direct-vent gas appliances. Direct-vent draws combustion air from the outdoors and vents to the outdoors.

**Example:**

Gas water heater	40,000	Btu/Hr
Vent-free fireplace +	33,000	Btu/Hr
<b>Total =</b>	<b>73,000</b>	<b>Btu/Hr</b>

4. Compare the maximum Btu/Hr the space can support with the actual amount of Btu/Hr used.

\_\_\_\_\_ Btu/Hr (maximum the space can support)  
 \_\_\_\_\_ Btu/Hr (actual amount of Btu/Hr used)

**Example:** 51,200 Btu/Hr (maximum the space can support)  
 73,000 Btu/Hr (actual amount of Btu/Hr used)

The space in the example is a confined space because the actual Btu/Hr used is more than the maximum Btu/Hr the space can support. You must provide additional fresh air. Your options are as follows:

- A.** Rework worksheet, adding the space of an adjoining room. If the extra space provides an unconfined space, remove door to adjoining room or add ventilation grills between rooms. See Ventilation Air From Inside Building.
- B.** Vent room directly to the outdoors. See Ventilation Air From Outdoors.
- C.** Install a lower Btu/Hr fireplace, if lower Btu/Hr size makes room unconfined.

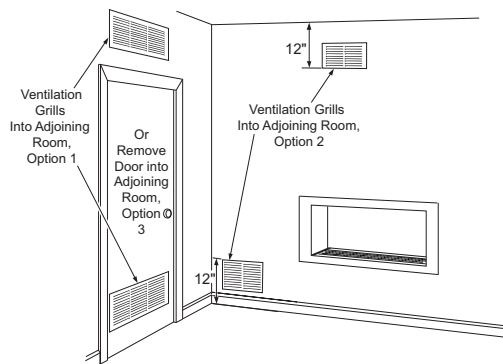
If the actual Btu/Hr used is less than the maximum Btu/Hr the space can support, the space is an unconfined space. You will need no additional fresh air ventilation.

**⚠ WARNING:** If the area in which the heater may be operated does not meet the required volume for indoor combustion air, combustion and ventilation air shall be provided by one of the methods described in the National Fuel Gas Code, ANSI Z223.1/NFPA 54, the International Fuel Gas Code, or applicable local codes.

### VENTILATION AIR

#### Ventilation Air From Inside Building

This fresh air would come from an adjoining unconfined space. When ventilating to an adjoining unconfined space, you must provide two permanent openings: one within 12" of the ceiling and one within 12" of the floor on the wall connecting the two spaces (see options 1 and 2, Figure 2). You can also remove door into adjoining room (see option 3, Figure 2). Follow the National Fuel Gas Code, ANSI Z223.1/NFPA 54, Air for Combustion and Ventilation for required size of ventilation grills or ducts.

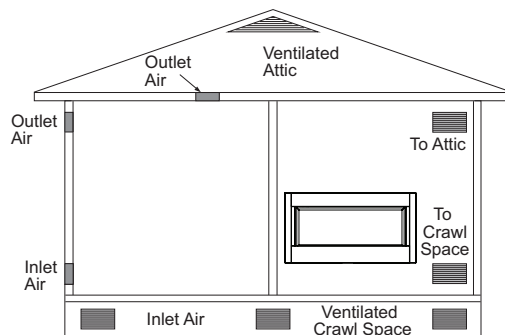


**Figure 2 - Ventilation Air from Inside Building (Fireplace may differ from actual model)**

#### Ventilation Air From Outdoors

Provide extra fresh air by using ventilation grills or ducts. You must provide two permanent openings: one within 12" of the ceiling and one within 12" of the floor. Connect these items directly to the outdoors or spaces open to the outdoors. These spaces include attics and crawl spaces. Follow the National Fuel Gas Code, ANSI Z223.1/NFPA 54, Air for Combustion and Ventilation for required size of ventilation grills or ducts.

**IMPORTANT:** Do not provide openings for inlet or outlet air into attic if attic has a thermostat-controlled power vent. Heated air entering the attic will activate the power vent.



**Figure 3 - Ventilation Air from Outdoors (Fireplace may differ from actual model)**

## INSTALLATION

**NOTICE:** This heater is intended for use as supplemental heat. Use this heater along with your primary heating system. Do not install this heater as your primary heat source. If you have a central heating system, you may run system's circulating blower while using heater. This will help circulate the heat throughout the house.

**⚠ WARNING:** A qualified service person must install fireplace. Follow all local codes.

**⚠ WARNING:** Never install the fireplace

- in a bedroom or bathroom
- in a recreational vehicle
- where curtains, furniture, clothing or other flammable objects are less than 36" from the front and 42" top of fireplace. For side clearances see Figure 7, page 8
- in high traffic areas
- in windy or drafty areas

**⚠ CAUTION:** This fireplace creates warm air currents. These currents move heat to wall surfaces next to fireplace. Installing fireplace next to vinyl or cloth wall coverings or operating heater where impurities (such as, but not limited to, tobacco smoke, aromatic candles, cleaning fluids, oil or kerosene lamps, etc.) in the air exist, may discolor walls or cause odors.

**Note:** Standoff spacers are attached to the sides and top of your fireplace, these spacers can be placed directly against wall or framing materials.

Use the dimensions shown for rough openings to create the easiest installation as shown in Figure 4.

**IMPORTANT:** Vent-free heaters add moisture to the air. Although this is beneficial, installing fireplace in rooms without enough ventilation air may cause mildew to form from too much moisture. See [Air for Combustion and Ventilation](#), page 5.

### CHECK GAS TYPE

Use the correct gas type (natural or propane/LP) for your fireplace. If your gas supply is not correct, do not install fireplace. Call dealer where you bought fireplace for proper type fireplace.

**⚠ WARNING:** This appliance is equipped for either natural gas or propane/LP gas but not both. Gas type is indicated on the rating plate. Field conversion is not permitted.

### INSTALLATION CLEARANCES

**⚠ WARNING:** Maintain the minimum clearances. If you can, provide greater clearances from floor, ceiling and adjoining wall.

Carefully follow the instructions below. This will ensure safe installation.

### CLEARANCES

Minimum clearances to combustibles for the fireplace are as follows:

* Back and sides	1"
Perpendicular walls	8"
Floor (From bottom of Fireplace)	0"
Ceiling (From top of opening)	42"
Top of Standoffs	0"

\* For back and sides of fireplace, do not pack with insulation or other materials.

### Hearth Extension

A hearth extension is not required with this fireplace. Any hearth extension used is for appearance only and does not have to conform to standard hearth extension installation requirements.

### FRAMING AND FINISHING

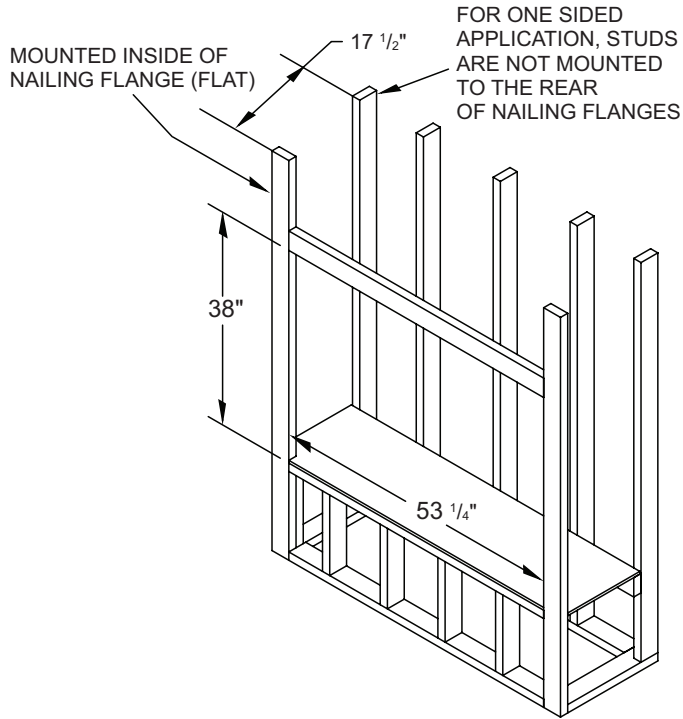
**Choose framing application accordingly. Figure 4, page 8 shows typical one sided framing. Figure 5, page 8 shows framing for see-thru installation. Note:** Kits F1029 and F1030 are required for see-thru application (See upgrading [LexingtonLights43](#) to see-thru application, page 13).

All minimum clearances must be met. Steel framing may be necessary or wood studs may be notched. Concrete board is provided for facing around the fireplace as shown in Figure 6, page 8.

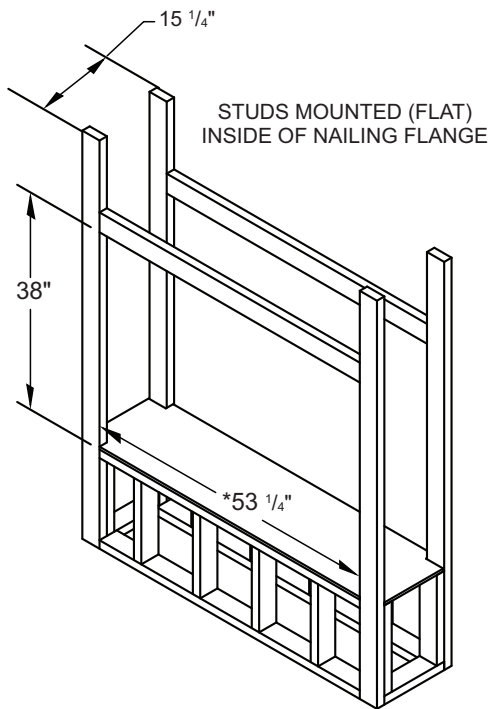
If you are using a separate combustible mantel piece, refer to Figure 7, page 8 for proper installation height. You can install noncombustible mantels at any height above the fireplace.

**NOTE:** To avoid heat-related finish damage, we recommend the use of high temperature paint (rated 175° F or higher) on the underside of the mantel.

# INSTALLATION *Continued*

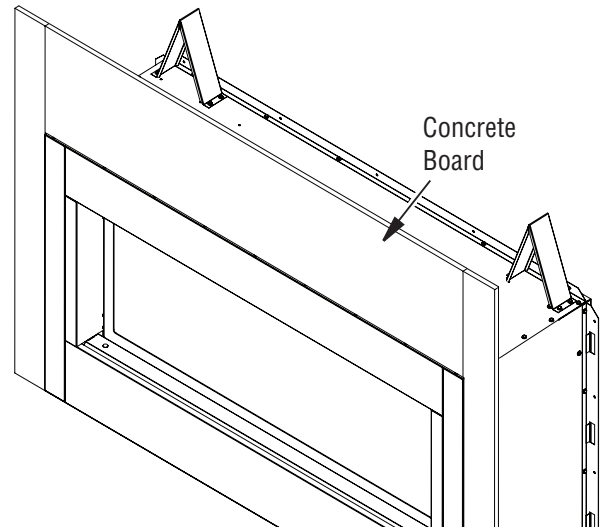


**Figure 4 - Framing Clearances for One Sided Application**

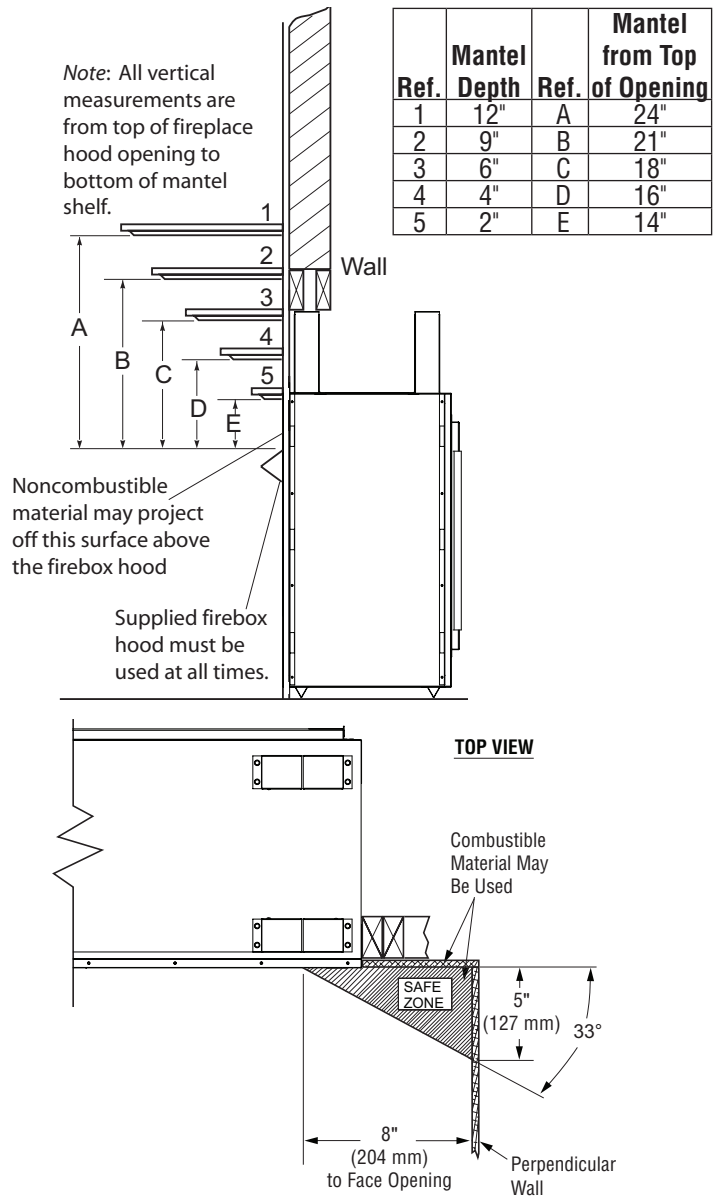


**Figure 5 - Framing Clearances for See-Thru Application**

\*Please refer to overall fireplace width (Figure 8, page 9) before rough framing construction.



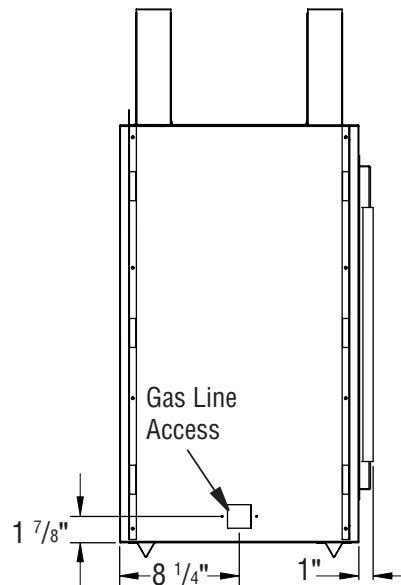
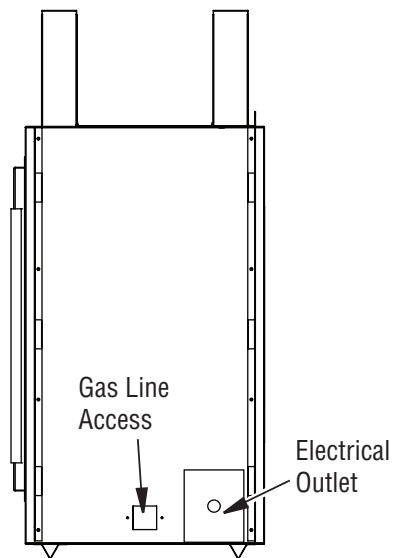
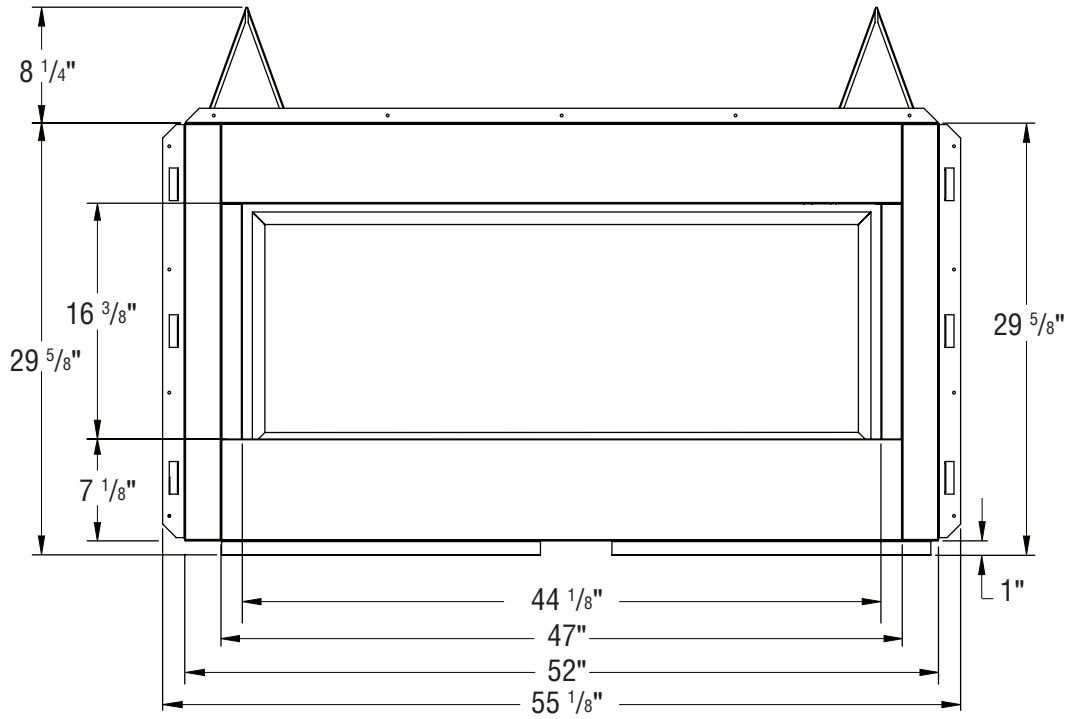
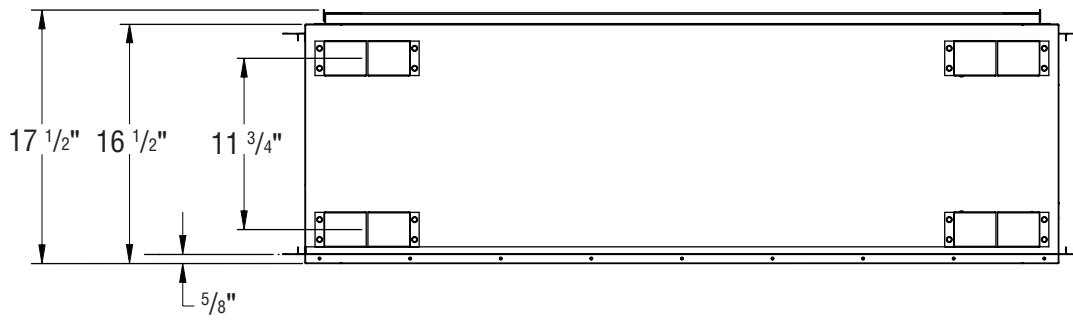
**Figure 6 - Installing Concrete Board**



**Figure 7 - Clearances for Combustible Mantels**



**INSTALLATION *Continued***



**Figure 8 - Lexington Lights 43 Series Dimensions**

## INSTALLATION *Continued*

### Mantel Clearances for Built-In Installation

If placing mantel above built-in fireplace, you must meet minimum clearance between mantel shelf and top of fireplace opening.

**NOTICE:** If your installation does not meet the minimum clearances shown, you must do one of the following:

- raise the mantel to an acceptable height
- remove the mantel

**NOTICE:** Surface temperatures of adjacent walls and mantels become hot during operation. Walls and mantels above the firebox may become hot to the touch. If installed properly, these temperatures meet the requirement of the national product standard. Follow all minimum clearances shown in this manual.

### ELECTRICAL WIRING INSTRUCTIONS

1. Remove electrical cover plate with bushing from left side of fireplace front by removing 2 sheet metal screws as shown in Figure 9.
2. Slide power source wiring through electrical bushing opening and electrical cover plate and make all necessary connections.
3. Slide all wiring connections in electrical housing as shown in Figure 9.
4. Secure electrical cover plate with screws previously removed.

**Note:** Electrical housing and cover plate have sharp edges. Wear protective gloves.

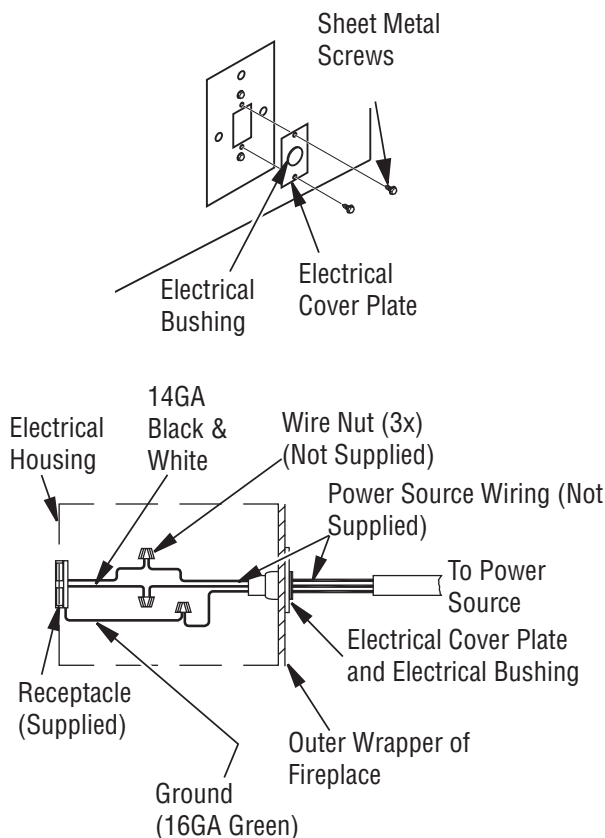


Figure 9 - Connecting Electricity

### CHECK GAS TYPE

Use proper gas type for the fireplace unit you are installing. If you have conflicting gas types, do not install fireplace. See retailer where you purchased the fireplace for proper fireplace according to your gas type.

### INSTALLING GAS PIPING TO FIREPLACE LOCATION

**⚠ WARNING:** A qualified service person must connect fireplace to gas supply. Follow all local codes.

**⚠ CAUTION:** Never connect propane/LP fireplace directly to the propane/LP supply. This fireplace requires an external regulator (not supplied). Install the external regulator between the fireplace and propane/LP supply.

### Installation Items Needed

Before installing fireplace, make sure you have the items listed below.

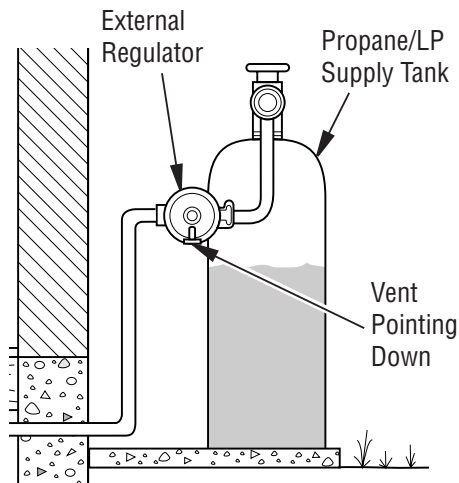
- external regulator for propane/LP unit only (supplied by installer)
- piping (check local codes)
- sealant (resistant to propane/LP gas)
- equipment shutoff valve \*
- test gauge connection \*
- sediment trap (optional)
- tee joint
- pipe wrench
- approved flexible gas line with gas connector (if allowed by local codes) (not provided)

\* An equipment shutoff valve with 1/8" NPT tap is an acceptable alternative to test gauge connection. Purchase the optional equipment shutoff valve from your dealer.

For propane/LP units, the installer must supply an external regulator. The external regulator will reduce incoming gas pressure. You must reduce incoming gas pressure to between 11" and 14" of water. If you do not reduce incoming gas pressure, heater regulator damage could occur. Install external regulator with the vent pointing down as shown in Figure 10, page 11. Pointing the vent down protects it from freezing rain or sleet.

**⚠ CAUTION:** Use only new, black iron or steel pipe. Internally-tinned copper tubing may be used in certain areas. Check your local codes. Use pipe of 1/2" diameter or greater to allow proper gas volume to fireplace. If pipe is too small, undue loss of volume will occur.

## INSTALLATION *Continued*



**Figure 10 - External Regulator on Propane/LP Supply Tank with Vent Pointing Down**

Installation must include an equipment shutoff valve, union and plugged 1/8" NPT tap. Locate NPT tap within reach for test gauge hook up. NPT tap must be upstream from fireplace (see Figure 10).

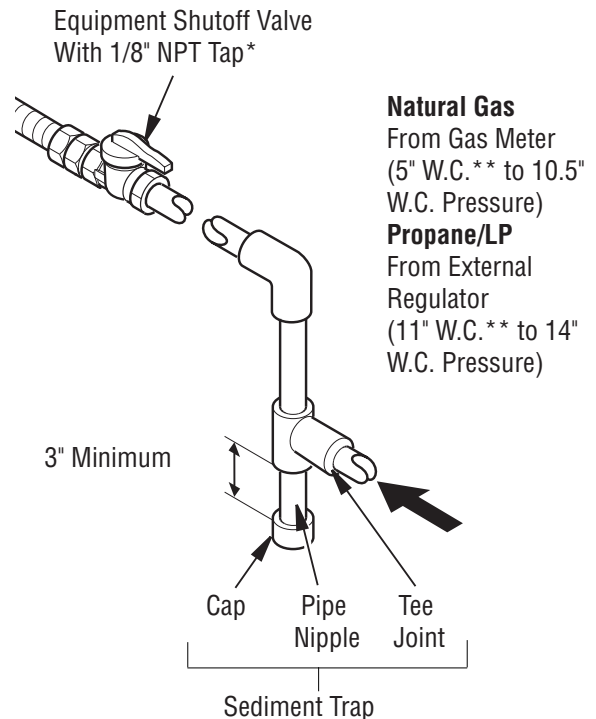
**IMPORTANT:** Install equipment shutoff valve in an accessible location. The equipment shutoff valve is for turning on or shutting off the gas to the appliance.

Check your building codes for any special requirements for locating equipment shutoff valve to fireplaces.

Apply pipe joint sealant lightly to male NPT threads. This will prevent excess sealant from going into pipe. Excess sealant in pipe could result in clogged fireplace valves. Never use sealant on flare threads.

**⚠ WARNING: Use pipe joint sealant that is resistant to liquid petroleum (LP) gas.**

We recommend that you install a sediment trap in supply line as shown in Figure 11. Locate sediment trap where it is within reach for cleaning. Install in piping system between fuel supply and fireplace. Locate sediment trap where trapped matter is not likely to freeze. A sediment trap traps moisture and contaminants. This keeps them from going into fireplace gas controls. If sediment trap is not installed or is installed wrong, fireplace may not run properly.



\* Purchase the optional equipment shutoff valve from your dealer.

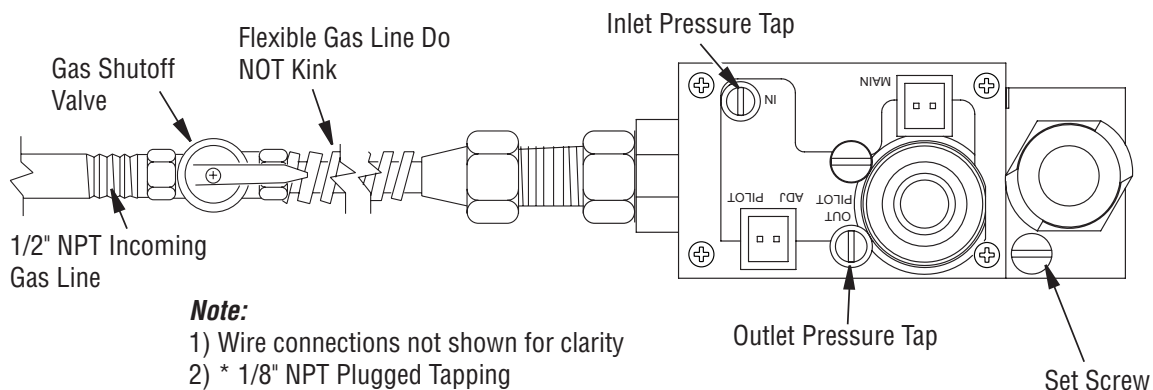
\*\* Minimum inlet pressure for purpose of input adjustment.

**Figure 11 - Gas Connection**

### CONNECTING FIREPLACE TO GAS SUPPLY

#### Installation Items Needed

- 5/16" hex socket wrench or nut-driver
  - sealant (resistant to propane/LP gas, not provided)
1. Route flexible gas line (provided by installer) from equipment shutoff valve to fireplace. Route flexible gas supply line through one of the access holes on side of fireplace.
  2. Attach flexible gas line from gas supply to control valve (see Figure 12).
  3. Check all gas connections for leaks. See [Checking Gas Connections](#), page 12.



**Figure 12 - Connecting Incoming Gas Line to Flex Gas Line**

## INSTALLATION *Continued*

### CHECKING GAS CONNECTIONS

**⚠ WARNING:** Test all gas piping and connections, internal and external to unit, for leaks after installing or servicing. Correct all leaks at once.

**⚠ WARNING:** Never use an open flame to check for a leak. Apply a noncorrosive leak detection fluid to all joints. Bubbles forming show a leak. Correct all leaks at once.

**⚠ CAUTION:** Make sure external regulator has been installed between propane/LP supply and fireplace. See guidelines under Connecting Fireplace to Gas Supply.

### PRESSURE TESTING GAS SUPPLY PIPING SYSTEM

#### Test Pressures In Excess Of 1/2 PSIG (3.5 kPa)

The appliance and its appliance main gas valve must be disconnected from the gas supply piping system during any pressure testing of that system at test pressures **in excess of** 1/2 psig (3.5 kPa).

1. Disconnect fireplace with its appliance main gas valve (control valve) and equipment shutoff valve from gas supply piping system. Pressures in excess of 1/2 psig (3.5 kPa) will damage fireplace regulator.
2. Cap off open end of gas pipe where equipment shutoff valve was connected.
3. Pressurize supply piping system by either opening propane/LP supply tank valve for propane/LP gas or opening main gas valve located on or near gas meter for natural gas or using compressed air.
4. Check all joints of gas supply piping system. Apply noncorrosive leak detection fluid to all joints. Bubbles forming show a leak.
5. Correct all leaks at once.
6. Reconnect fireplace and equipment shutoff valve to gas supply. Check reconnected fittings for leaks.

#### Test Pressures Equal To or Less Than 1/2 PSIG (3.5 kPa)

The appliance must be isolated from the gas supply piping system by closing its equipment shutoff valve during any pressure testing of the gas supply piping system at test pressures **equal to or less than** 1/2 psig (3.5 kPa).

1. Close equipment shutoff valve (see Figure 13).
2. Pressurize supply piping system by either opening propane/LP supply tank valve for propane/LP gas or opening main gas valve located on or near gas meter for natural gas or using compressed air.
3. Check all joints from gas meter to equipment shutoff valve for natural gas or propane/LP supply to equipment shutoff valve for propane/LP (see Figures 14 or 15). Apply noncorrosive leak detection fluid to all joints. Bubbles forming show a leak.
4. Correct all leaks at once.

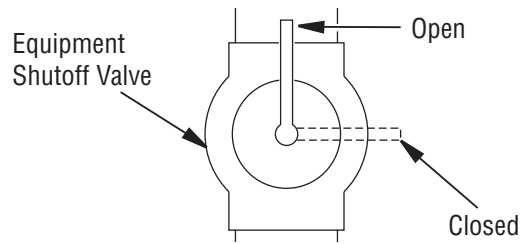


Figure 13 - Equipment Shutoff Valve

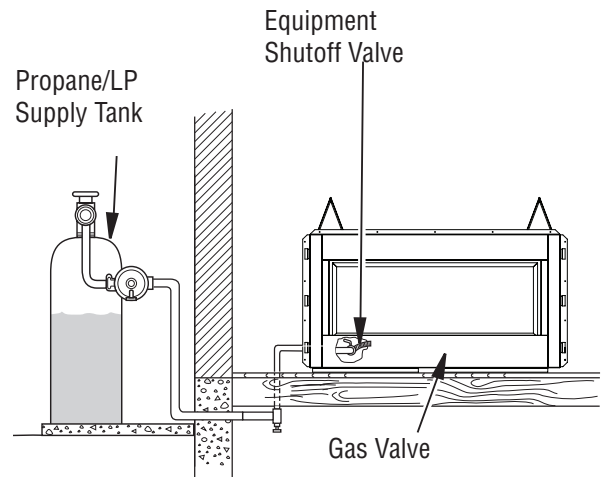


Figure 14 - Checking Gas Joints for Propane/LP Gas Fireplace

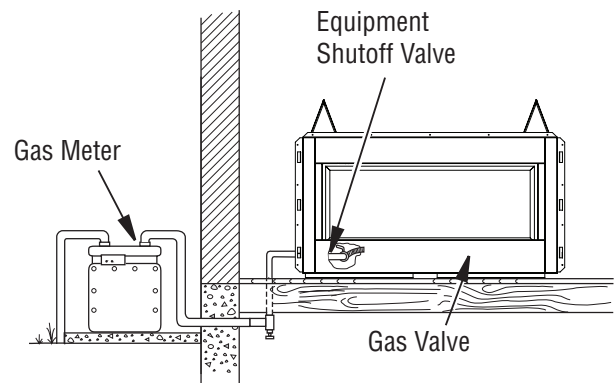


Figure 15 - Checking Gas Joints for Natural Gas Fireplace

### PRESSURE TESTING FIREPLACE GAS CONNECTIONS

1. Open equipment shutoff valve (see Figure 13).
2. Open main gas valve located on or near gas meter for natural gas or open propane/LP supply tank valve.
3. Make sure control knob of fireplace is in the OFF position.
4. Check all joints from equipment shutoff valve to gas control valve (see Figures 14 or 15). Apply noncorrosive leak detection fluid to all joints. Bubbles forming show a leak.
5. Correct all leaks at once.
6. Light fireplace (see *Operating Fireplace*, page 19). Check all other internal joints for leaks.
7. Turn off fireplace (see *To Turn Off Gas to Appliance*, page 19).

## INSTALLATION *Continued*

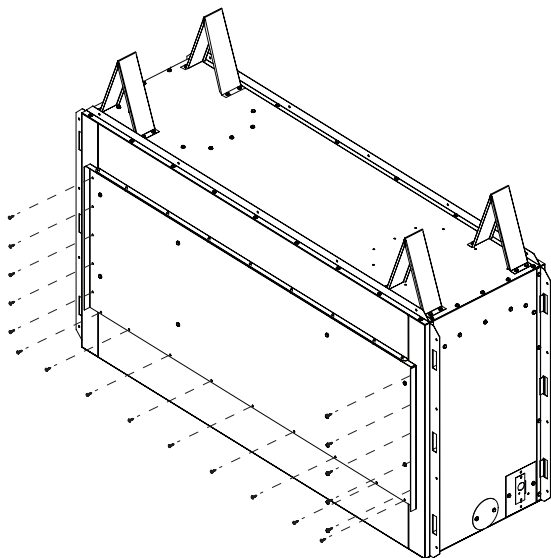
### FINISHING FIREPLACE FOR INSTALLATION

LexingtonLights43 series fireplace come with the rear panel semi-installed. If you will be using the fireplace for a one sided regular application, you will need to finish the installation of the rear panel. If you will be upgrading the fireplace to a see-thru, the rear panel will need to be removed (See [Upgrading LexingtonLights43 to See-Thru Application](#)).

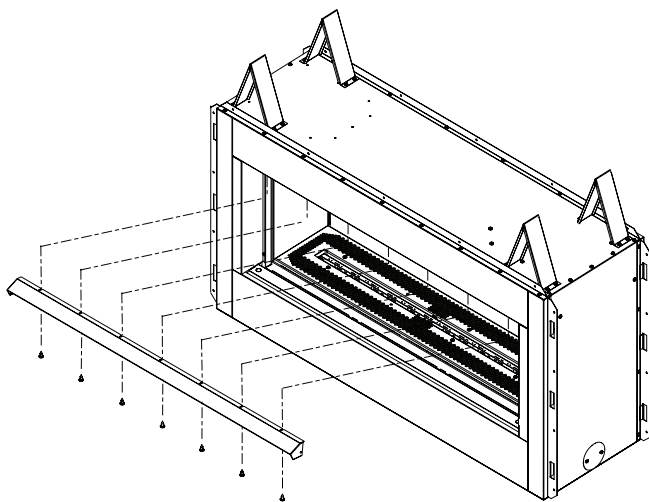
1. Using self-tapping screws provided and holes on rear panel as a guide, screw the rear panel to the fireplace as shown in Figure 16.

### INSTALLING HOOD

1. Loosen screws at top of face opening and slide hood through screws as shown in Figure 17.
2. Tighten screws securing hood to fireplace.



**Figure 16 - Installing Rear Panel for Regular Applications**

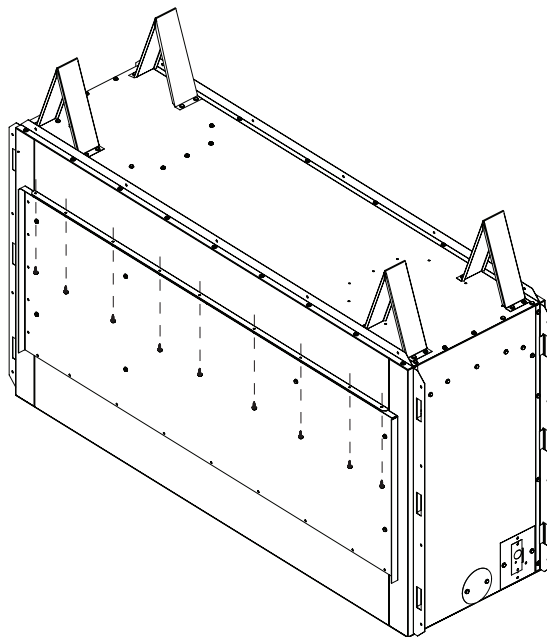


**Figure 17 - Installing Hood**

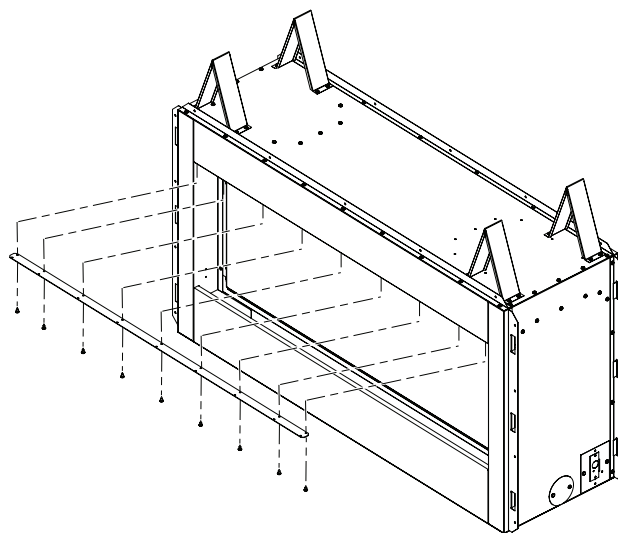
### UPGRADING LEXINGTONLIGHTS43 TO SEE-THRU APPLICATION

#### Removing Rear Panel

1. In the rear of the fireplace, locate screws at top of rear panel and remove as shown in Figure 18. Discard screws and rear panel.
2. Unscrew mount bracket from top face as shown in Figure 19. Discard mounting bracket and replace screws.



**Figure 18 - Removing Rear Panel for See-Thru Applications**

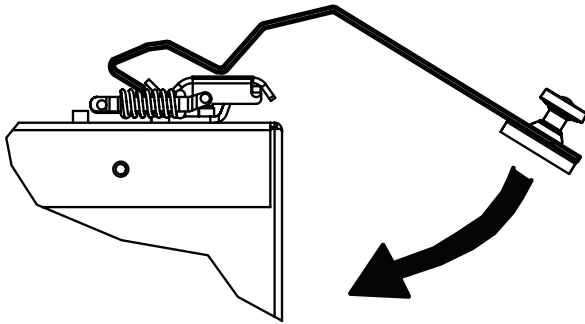


**Figure 19 - Removing for See-Thru Applications**

## INSTALLATION *Continued*

### Removing False Door

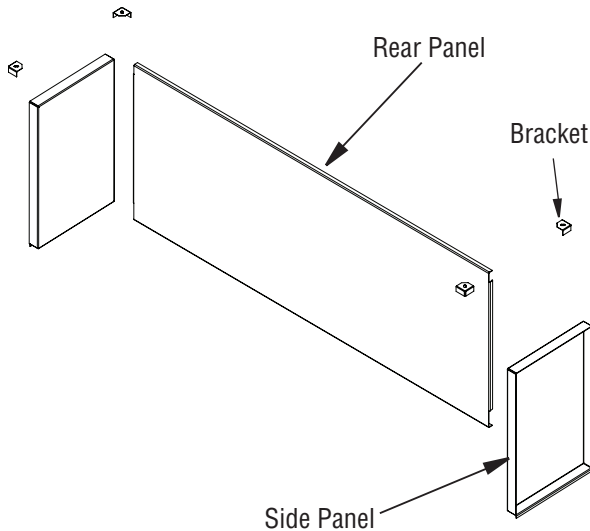
1. In the rear of the fireplace, Unlock 3 door latches on top of firebox using your fingers or the latch opener provided.
2. Hook opener over latch as shown in Figure 20. Swing the bottom of the opener down toward the door. You will not need to pull down.
3. Tilt open false door 45° from the top of firebox and lift up to release door from retaining channel.



**Figure 20 - Latch Opener**

### Removing Rear Interior Wall

1. Through firebox opening in the front of the fireplace, unscrew 4 corner brackets from the firebox top (See Figure 21).
2. Remove 2 side walls and then the rear wall. Discard rear wall.
3. Replace 2 side walls and reinstall the corner brackets.



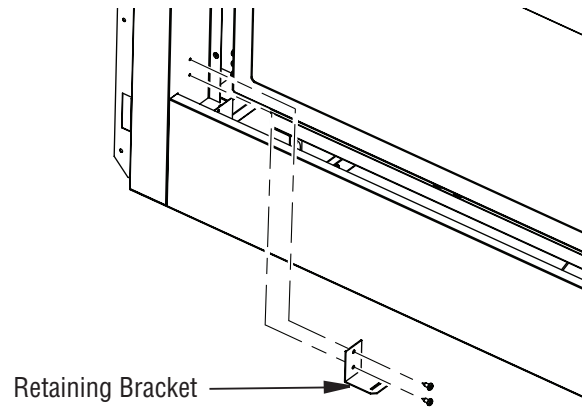
**Figure 21 - Removing Rear Interior Wall for See-Thru Applications**

### Installing Access Door Retaining Brackets

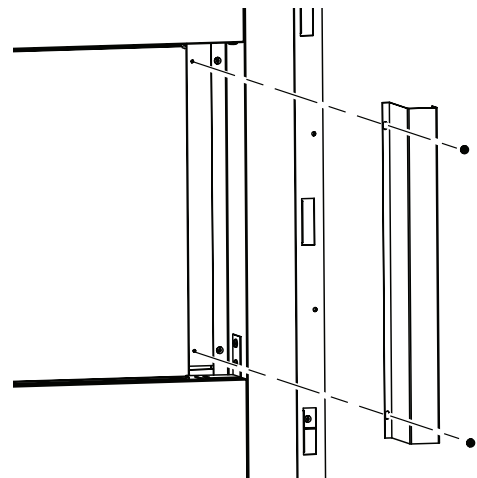
1. Screw access door retaining brackets into the inner side face using 2 screws on both the left and right side as shown in Figure 22.

### Installing Side Face Filler

1. Screw side face filler into firebox side baffle using 2 screws on both the left and right side as shown in Figure 23.



**Figure 22 - Installing Access Door Retaining Brackets for See-Thru Applications**



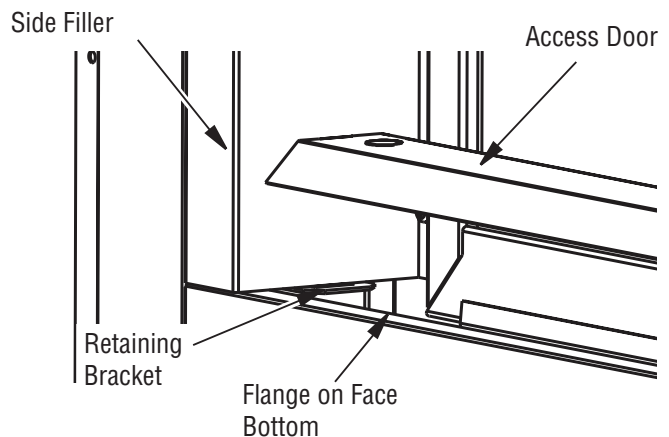
**Figure 23 - Installing Side Face Filler for See-Thru Applications**

### Installing Access Door

1. Place access door into rectangular opening in front of the glass door with the slanted side facing forward. The slanted surface will slide underneath the flange of the bottom face. Insert tabs on side of access door into slots on retaining brackets (See Figure 24).

### Installing Hood

1. If required, install hood as shown on Figure 17, page 13.



**Figure 24 - Access Door for See-Thru Applications**

## INSTALLATION *Continued*

### GLASS PEBBLE INSTALLATION

**⚠ WARNING: Do not change or substitute glass pebbles provided with this fireplace. If replacing, use only replacement glass pebbles. See Parts page 27.**

**⚠ WARNING: Do not block pilot ports with glass pebbles.**

**⚠ WARNING: Do not place the glass pebbles on the burner, only on the burner tray as illustrated in Figure 25.**



Place Glass Pebbles on the pebble tray in a single orderly layer.

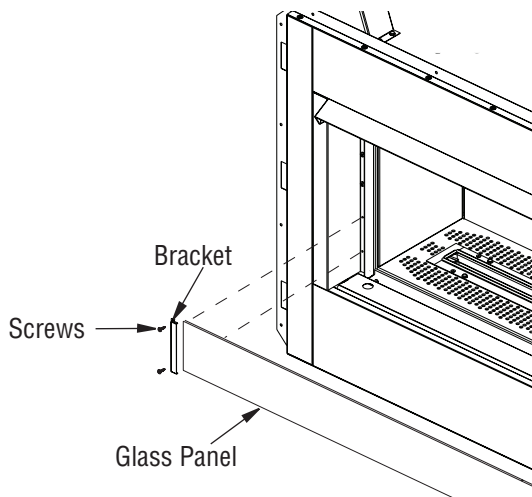
**Figure 25 - Placing Glass Pebbles**

Clear glass pebbles are included with your fireplace. Install the glass pebbles before installation of optional Draft Shield Kit, LV43DS (F1031).

1. Place glass pebbles in a single layer evenly on the pebble pan. Make certain that the correct media is used. If crushed glass or other media is used, replaced it with the proper media listed on the price list. Make certain the media is placed precisely as indicated in this instruction manual (single layer of pebbles in straight rows) and all glass remains on the pebble tray with no glass at all on the burner.

### OPTIONAL DRAFT SHIELD KIT INSTALLATION (F1031)

The glass panel assembly should be installed after the fireplace is completely framed and finished. The brackets are attached to the front side face of the fireplace using two screws as shown in Figure 25a. Position the glass panel in the bracket so that it is securely in place.



**Figure 25a - Installing/Removing Glass Panel**

### REPLACING LIGHT BULBS

1. Unplug power
2. Remove access door (see Figure 24, page 14).
3. Remove glass panel if installed (see Figure 25a).
4. Remove rear interior wall (see Figure 21, page 14).
5. Remove glass pebbles (see Figure 25).
6. Remove six screws holding pebble pan.
7. Using a small slotted screwdriver, carefully slide it under edge of light cover and pry it open.
8. Pull bulb out carefully and replace with bulb G9 120V/20W.
9. To replace, follow steps in the reverse order.

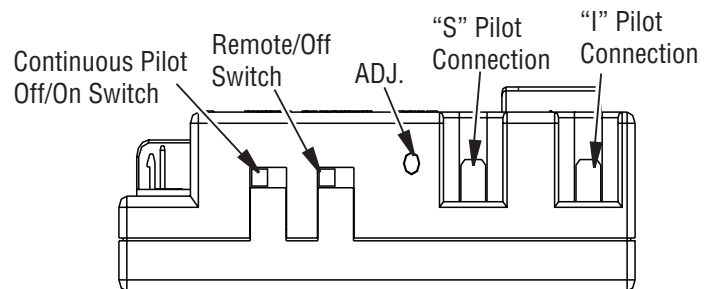
### GAS CONTROL MODULE SYSTEM

The module has 2 special features built into the system.

#### Continuous Pilot Feature

This allows the change from a spark to pilot system to a standing pilot system

1. There is a switch located on the right side of the module that reads CONTINUOUS PILOT ON/OFF. This switch selects the pilot's mode of operation (Figure 26).
2. When the continuous pilot switch is in the OFF position and the appliance rocker switch is turned ON, the pilot will spark and light. When the appliance rocker switch is turned OFF, the pilot will shut OFF when the main burner shuts OFF.
3. When the continuous pilot switch is in the ON position and the appliance rocker switch is turned ON, the pilot will spark and light. When the appliance rocker switch is turned OFF, the pilot will stay ON when the main burner shuts OFF.

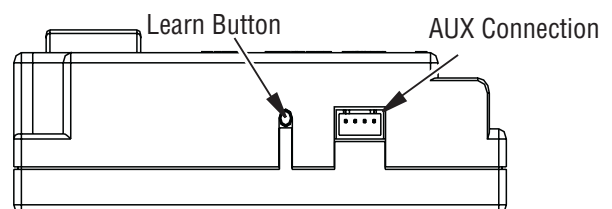


**Figure 26 - Gas Module Right Side**

#### Remote Control Feature

The module has a built in remote control receiver that allows the user to program the remote transmitter at any time during or after the installation of the burner.

1. There is a switch located on the right side of the module that reads REMOTE/OFF (Figure 27).
2. When the remote/off switch is in the OFF position, the burner will operate from the rocker switch or wall switch connected to the two BROWN wires on the module.
3. When the remote/off is in the REMOTE position the burner will operate from the Remote Control transmitter.



**Figure 27 - Gas Module Left Side**

## GAS CONTROL MODULE SYSTEM *Continued*

**NOTE:** The module must be programmed to the Remote Control transmitter.

- To program the module (make sure the system has power), locate the learn button on left side as shown in Figure 27, page 15. Press and release the learn button. There will be a beep sound from the module. Then press any button on the remote transmitter. Once the module's internal receiver accepts the transmitter code, there will be a series of confirming beeps.
- The remote system is ready for use.

**NOTE:** Make sure the valve module and light module are plugged into the electric duct assembly.

### BATTERY BACK-UP

This fireplace is equipped with a battery back-up. If the power was to go out on the fireplace, the battery back-up allows the fireplace to remain operational. Make sure to periodically check the condition of the four AA batteries used for the battery back-up.

## REMOTE CONTROL OPERATION

This remote control system was developed to provide a safe, reliable, and user-friendly remote control system. The system can be operated manually from the transmitter.

The transmitter operates with (4) AAA 1.5V batteries that are included. Install the batteries supplied with the unit into the battery compartment. It is recommended that ALKALINE batteries always be used for this product. Be sure the batteries are installed with the (+) and (-) ends facing the correct direction.

When you start up the remote, if a low battery signal appears or if the LCD screen does not illuminate when you touch it, check battery position and if the batteries are fully charged.

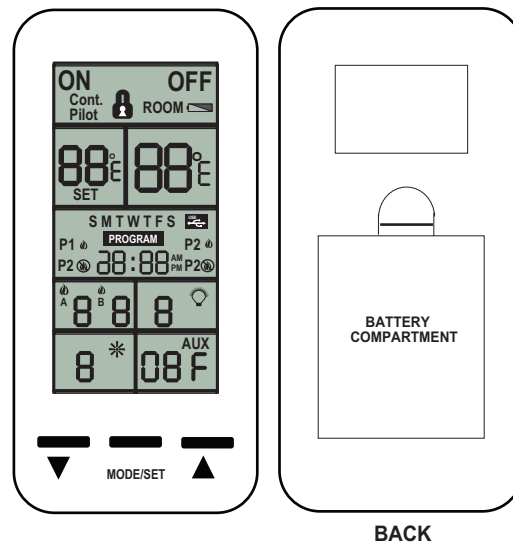
### TOUCH SCREEN LCD AND BUTTON LAYOUT

#### Functional Description

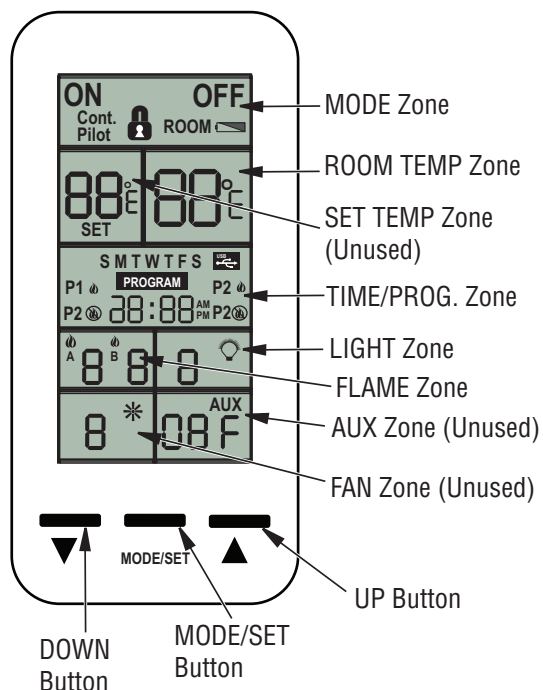
**Note:** All function adjustments will be automatically accepted 15 seconds after pressing a given touch zone or button. The user may press the MODE/SET button to immediately accept the adjustment manually.

#### Day and Time Display

- The current day of week and time of day will be continuously displayed in the TIME/PROG Zone (except during Setup operations).
- The day of week will be displayed as one of the following: S, M, T, W, T, F, S
- The time of day will be in 12-hour AM, 12-hour PM format. Midnight will be displayed as 12:00am.
- Day/Time Setup:
  - Press and hold the MODE Zone or the MODE/SET Button for 5 seconds to enter Day/Time Setup.
  - Press the UP or DOWN Buttons to adjust the day of week (press the MODE/SET Button or wait for 15 seconds for adjustment to be accepted, then enter hour of day adjustment).
  - Press the UP or DOWN Buttons to adjust the hour of the day. The time will advance in 1-hour increments; AM and PM will change when the hour advances to 12:00 midnight and 12:00 noon respectively (press the MODE/SET Button or wait for 15 seconds for adjustment to be accepted, then enter minute of hour adjustment).
  - Press the UP or DOWN Buttons to adjust the minute of the hour. The time will advance in 1-minute increments (press the MODE/SET Button or wait for 15 seconds and the transmitter will exit Day/Time Setup and return to normal operation).
  - LCD Displays – when in Day/Time Setup:



**Figure 28 - Remote Control Battery Compartment**



**Figure 29 - Touch Screen Settings**



## REMOTE CONTROL OPERATION *Continued*

- MODE Zone: Blank
- ROOM TEMP Zone: Blank
- SET TEMP Zone: Blank
- LIGHT Zone: Blank
- FAN Zone: Blank
- TIME/PROG Zone: Day of Week, or Time of Day will Flash
- AUX Zone: Blank
- FLAME Zone: Blank
- Temperatures may be displayed in degrees F (factory default) or degrees C. Press the up and down buttons simultaneously to change between degrees F. and C.

### MODES OF OPERATION

#### Operation modes:

- MANUAL OFF
- MANUAL ON

The modes may be cycled in the order above by pressing the MODE Zone or the MODE/SET Button.

#### MANUAL OFF MODE

- Transmits flame OFF command.
- LCD Displays:
  - MODE Zone: OFF is displayed
  - ROOM TEMP Zone: Measured temperature is displayed
  - SET TEMP Zone: Blank
  - LIGHT Zone: LIGHT and light setting level is displayed
  - FAN Zone: Blank
  - TIME/PROG Zone: Current day indicator and current time is displayed
  - AUX Zone: Blank (AUX function is omitted on this control)
  - FLAME Zone: Blank

#### MANUAL ON MODE:

- Transmits flame ON command
- LCD Displays:
  - MODE Zone: ON is displayed
  - ROOM TEMP Zone: Measured temperature is displayed
  - SET TEMP Zone: Blank
  - LIGHT Zone: LIGHT and light setting level is displayed
  - FAN Zone: FAN and fan setting level is unused
  - TIME/PROG Zone: Current day indicator and current time is displayed
  - AUX Zone: Blank (AUX function is omitted on this control)
  - FLAME Zone: A&B Flame Icons and flame setting level numbers are displayed

#### THERMOSTAT Mode:

#### **NOTE: THE FACTORY DEFAULT SETTING DISABLES THERMOSTAT MODE.**

- Will cycle flame on and off based on room and set temperatures. Will transmit ON command if SET TEMP (+SWING) is higher than ROOM TEMP and will transmit OFF command if SET TEMP (-SWING) is lower than ROOM TEMP.
- Built-in thermostat will measure room temperature.
- All programming should be written for deg. F and converted to deg. C when selected.

- Temperatures may be displayed in degrees F (factory default) or degrees C. Press the UP and DOWN Buttons simultaneously to change between degrees F and C.
- SET TEMP: While in THERMOSTAT mode, press the UP or DOWN Button to change the SET TEMP (45-90 deg. F, 7-32 deg. C); the new set temperature will automatically be accepted after 2 seconds. The factory default SET TEMP is 45 deg. F.
- SWING Temperature: This model does not allow for SWING temperature adjustment. This model utilizes thermostatic flame modulation that will modulation the main flame based on the difference between room temperature and set temperature:
  - o Important - factory SWING TEMPERATURE setting is 2 degrees. The thermostatic flame modulation feature will not allow this SWING to be changed.

#### EXAMPLE:

Set Temperature	Room Temp.	Flame Level
	74F	OFF
	73F	Level 1
Set Temperature (72)	72F	Level 2
	71F	Level 3
	70F	Level 4
	69F	Level 5
	68F	Level 6
	67F	Level 7

- Manual Flame Adjustment while in THERMOSTAT mode: Flame-A will be the only flame setting that is adjusted automatically. Flame-A and Flame-B may be manually adjusted while in thermostat mode. If Flame-A is manually adjusted while in thermostat mode, it will override the automatic flame setting until the flame cycles off, then back ON thermostatically; when the flame cycles ON again, automatic flame adjustment will resume (Flame-B setting will remain as-set by the user). Automatic flame adjustment will also resume if the operational mode is cycled out of, then back into THERMOSTAT mode or if the SET temperature is changed.
- THERMOSTAT OFF LCD Displays:
  - o MODE Zone: THERMO and OFF is displayed
  - o ROOM TEMP Zone: Measured temperature is displayed
  - o SET TEMP Zone: SET TEMP is displayed
  - o LIGHT Zone: LIGHT and light setting level is displayed
  - o FAN Zone: Blank
  - o TIME/PROG Zone: Current day indicator and current time is displayed
  - o AUX Zone: Blank (AUX function is omitted on this control)
  - o FLAME Zone: Blank
- THERMOSTAT ON LCD Displays:
  - o MODE Zone: THERMO and ON are displayed
  - o ROOM TEMP Zone: Measured temperature is displayed
  - o SET TEMP Zone: SET TEMP is displayed

## REMOTE CONTROL OPERATION *Continued*

- o LIGHT Zone: LIGHT and light setting level is displayed
- o FAN Zone: FAN and fan setting level is displayed
- o TIME/PROG Zone: Current day indicator and current time is displayed
- o AUX Zone: Blank (AUX function is omitted on this control)
- o FLAME Zone: A&B Flame Icons and flame setting level numbers are displayed

### Thermostat Disable Feature

- The Thermostat Mode (described above) may be enabled if desired, but is disabled for applications where a thermostat is not allowed or undesirable. THE FACTORY DEFAULT IS DISABLED.
- When Thermostat Mode is Disabled:
  - o The Modes of operation will cycle between MANUAL ON and MANUAL OFF (omitting THERMO).
  - o Program Operation (described below) is also disabled.
  - o The SET TEMP zone will be blank.
  - o The room temperature will still be measured & displayed in the ROOM TEMP Zone.
  - o The TIME/PROG zone will continue to display the Clock and Day of week, but none of the icons associated with Program Mode will be displayed.
- To disable or re-enable the Thermostat, the transmitter must be in MANUAL OFF Mode, then press and hold the SET TEMP Zone and the DOWN Button simultaneously for 10-seconds. The LCD screen will go blank except either THERMO and OFF or THERMO and ON will flash 3-times (0.5-seconds OFF, 0.5-seconds ON) to indicate the change has been made

### FLAME - A (OR MAIN) ADJUSTMENT

- Transmits a flame height setting command to the control module to adjust the Flame-A height.
- Available settings are 1-7 with a factory default of 7. If the Flame-A setting is changed during operation (either manually or automatically), the control will remember and use the adjusted setting on subsequent manual ON cycles (Flame-A setting memory).
- While in MANUAL ON, or PROGRAM ON modes, press the FLAME Zone to enter Flame-A Adjustment, then press the UP or DOWN buttons to raise and lower the flame; press the MODE/SET Button or wait for 15 seconds to accept the new setting.
- LCD Display: When setting the Flame-A height, the Flame-A icon, and Flame-A setting number will flash in the FLAME Zone.

### LIGHT ADJUSTMENT

- Transmits a light setting command to the control module to adjust the light output level.
- Available settings are 0 (off) – 6 with a factory default of 0 (off).
- While in any mode of operation, press the LIGHT Zone to enter Light Adjustment, then press the UP or DOWN buttons to raise or lower the light output; press the MODE/SET Button or wait for 15 seconds to accept the new setting.
- LCD Displays:
  - When raising or lowering the light output level with the UP or DOWN buttons, the light icon and light setting number will flash in the LIGHT Zone.

### CONTINUOUS PILOT OPERATION

- To activate or deactivate the Continuous Pilot Feature, press and hold the MODE/SET and UP Buttons simultaneously for 5 seconds.
- LCD Display: When activated, CONT. PILOT will be displayed in the MODE Zone.

### CHILD-LOCK OPERATION

- Child-Lock operation prevents any user input to the transmitter. No mode of operation or feature may be adjusted when Child-Lock is activated. All automatic functions will continue normally.
- To activate or deactivate the Child-Lock feature, press and hold the MODE/SET and DOWN Buttons simultaneously for 5 seconds.
- LCD Displays:
  - When activated, the LOCK icon will appear in the MODE Zone.
  - If any touch-zone or button is pressed when activated, the LCD backlight will illuminate and the LOCK icon will flash for 5 seconds in the MODE Zone.

### SENSOR SAFETY OVERRIDE

- Will only operate if the control is in MANUAL OFF mode.
- Press and hold the FLAME Zone and the UP Button simultaneously activate the sensor safety override feature.
- The module will ignore any sensor faults, continually emit an igniter spark, and energize the PILOT operator output.
- When the buttons are released, the control will immediately return to MANUAL OFF mode.
- LCD Display:
  - When the Sensor Safety Override feature is activated, CONT. PILOT will flash on the LCD screen.

### COMMUNICATION SAFETY

- In manual ON and program modes of operation, the transmitter will send a communication safety transmission every 15 - minutes. This signal is further processed by the ignition control module to verify the transmitter is communicating properly.

## OPERATING FIREPLACE

### FOR YOUR SAFETY READ BEFORE LIGHTING

**⚠ WARNING: If you do not follow these instructions exactly, a fire or explosion may result causing property damage, personal injury or loss of life.**

- A. This appliance is equipped with an ignition device which automatically lights the pilot. Do not light pilot by hand.
- B. BEFORE LIGHTING smell all around the appliance area for gas. Be sure to smell next to the floor because some gas is heavier than air and will settle on the floor.

#### WHAT TO DO IF YOU SMELL GAS

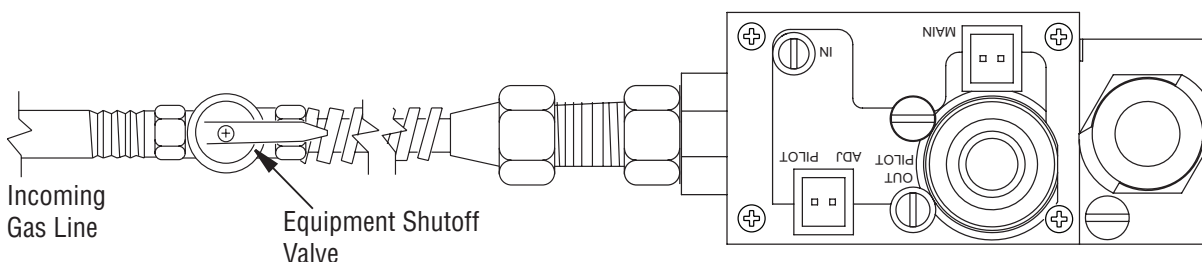
- Do not try to light any appliance.
  - Do not touch any electric switch; do not use any phone in your building.
  - Immediately call your gas supplier from a neighbor's phone. Follow the gas supplier's instructions.
  - If you cannot reach your gas supplier, call the fire department.
- C. Do not use this appliance if any part has been under water. Immediately call a qualified service technician to inspect the appliance and to replace any part of the control system and any gas control which has been under water.

### LIGHTING INSTRUCTIONS

**⚠ NOTICE: During initial operation of new heater, paint will give off a paper-burning smell. Orange flame will also be present. Open damper or window to vent smell. This will only last a few hours.**

This appliance requires 120V electricity for normal operation. Control module should be plugged into electrical outlet located underneath firebox bottom. Back up battery supply is available for power outages.

1. STOP! Read the safety information, column 1.
2. Make sure equipment shutoff valve is fully open.
3. Turn safety shutoff switch to the OFF position.
4. Remove access door.
5. Turn equipment shutoff valve clockwise to the OFF position (see Figure 30). Do not force.



**Figure 30 - Turning Equipment Shutoff Valve to the OFF Position**

6. Wait five (5) minutes to clear out any gas. Then smell for gas, including near the floor. If you smell gas, STOP! Follow "B" in the safety information. If you don't smell gas, go to the next step.
7. Turn equipment shutoff valve counterclockwise to the ON position. Do not force.
8. Replace access door.
9. Turn on all electric power to appliance.
10. Turn safety shutoff switch to the ON position.
11. Visually locate pilot. Ignitor should begin to spark and main burner should ignite once flame appears at pilot.
  - If lighting appliance for the first time each season, it may take several attempts before supply gas can reach pilot and main burners.
  - If appliance will not stay lit after several attempts, follow instructions under To Turn Off Gas To Appliance and call your service technician or gas supplier.

**⚠ CAUTION: Do not try to adjust heating levels by using the equipment shutoff valve.**

### TO TURN OFF GAS TO APPLIANCE

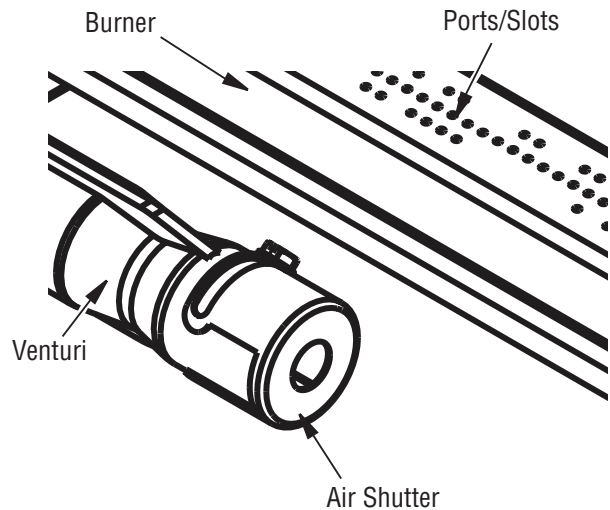
1. Turn off safety shutoff switch.
2. Turn off all electric power to appliance if service is to be performed.
3. Remove access door.
4. Turn equipment shutoff valve clockwise to OFF. Do not force.
5. Replace access door.

## CLEANING AND MAINTENANCE

**⚠ WARNING: Turn off fireplace and let cool before cleaning.**

**⚠ CAUTION: You must keep control areas, burner and circulating air passageways of fireplace clean. Inspect these areas of fireplace before each use. Have fireplace inspected yearly by a qualified service person. Fireplace may need more frequent cleaning due to excessive lint from carpeting, bedding material, pet hair, etc.**

**⚠ WARNING: Failure to keep the primary air opening(s) of the burner(s) clean may result in sooting and property damage.**



*Figure 31 - Injector Holder On Outlet Burner Tube*

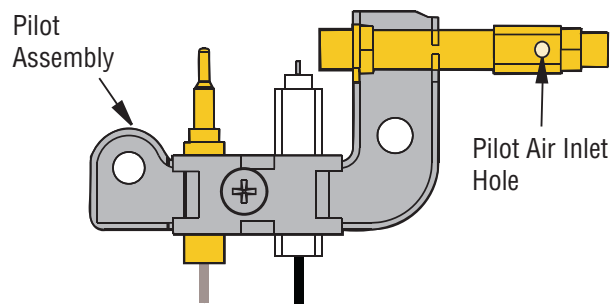
### BURNER INJECTOR HOLDER AND PILOT AIR INLET HOLE

The primary air inlet holes allow the proper amount of air to mix with the gas. This provides a clean burning flame. Keep these holes clear of dust, dirt, lint and pet hair. Clean these air inlet holes prior to each heating season. Blocked air holes will create soot. We recommend that you clean the unit every three months during operation and have heater inspected yearly by a qualified service person.

We also recommend that you keep the burner tube and pilot assembly clean and free of dust and dirt. To clean these parts we recommend using compressed air no greater than 30 PSI. Your local computer store, hardware store or home center may carry compressed air in a can. If using compressed air in a can, please follow the directions on the can. If you don't follow directions on the can, you could damage the pilot assembly.

1. Shut off the unit, including the pilot. Allow the unit to cool for at least thirty minutes.
2. Inspect burner, air shutter and orifice for dust and dirt (see Figures 31 and 32).
3. Blow air through the ports/slots and holes in the burner.
4. Check the orifice located at the end of the burner tube again. Remove any large particles of dust, dirt, lint or pet hair with a soft cloth or vacuum cleaner nozzle.
5. Blow air into the primary air holes on the injector holder.
6. In case any large clumps of dust have now been pushed into the burner repeat steps 3 and 4 above.

Clean the pilot assembly also. A yellow tip on the pilot flame indicates dust and dirt in the pilot assembly. There is a small pilot air inlet hole on the pilot assembly (see Figure 32). With the unit off, lightly blow air through the air inlet hole. You may blow through a drinking straw if compressed air is not available.



*Figure 32 - Pilot Inlet Air Hole*

## INSPECTING BURNERS

Check pilot flame pattern and burner flame patterns often.

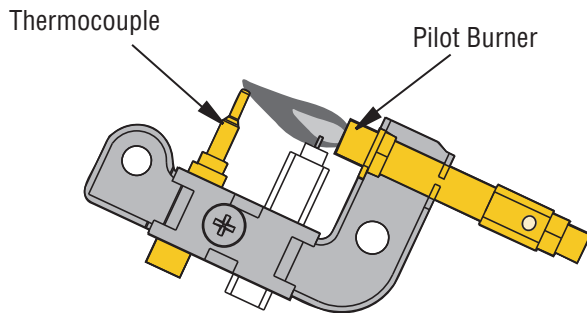
### PILOT FLAME PATTERN

Figure 33 shows a correct pilot flame pattern. Figure 34 shows an incorrect pilot flame pattern. The incorrect pilot flame is not touching the thermocouple. This will cause the thermocouple to cool. When the thermocouple cools, the heater will shut down.

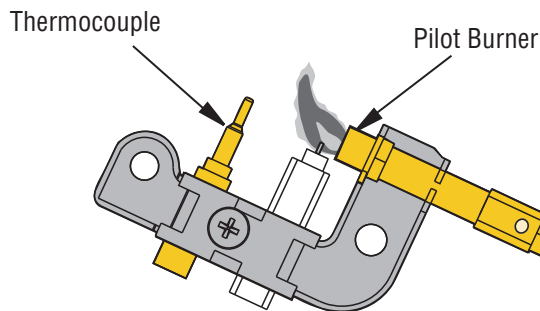
If pilot flame pattern is incorrect, as shown in Figure 34.

- turn heater off (see [To Turn Off Gas to Appliance](#), page 19)
- see [Troubleshooting](#), page 23

**Note:** The pilot flame on natural gas units will have a slight curve, but flame should be blue and have no yellow or orange color.



**Figure 33 - Correct Pilot Flame Pattern (Your pilot may vary from pilots shown)**



**Figure 34 - Incorrect Pilot Flame Pattern (Your pilot may vary from pilots shown)**

### BURNER PRIMARY AIR HOLES

Air is drawn into the burner through the holes in the fitting at the burner entrance. These holes may become blocked with dust or lint. Periodically inspect these holes for any blockage and clean if needed. Blocked air holes will create soot.

### MAIN BURNER

Periodically inspect all burner flame holes with the fireplace running. Some burner flame holes may become blocked by debris or rust, with no flame present. If so, turn off fireplace and let cool. Remove blockage. Blocked burner flame holes will create soot.

### BURNER FLAME PATTERN

**WARNING:** If yellow tipping occurs, your fireplace could produce increased levels of carbon monoxide.

**NOTICE:** Do not mistake orange flames with yellow tipping. Dirt or other fine particles enter the fireplace and burn causing brief patches of orange flame.

Burner flames will be steady, not lifting or floating—a bright yellow burner flame that will be blue next to the burner. Flame patterns will be different from unit to unit and will vary depending on installation type and weather conditions. This can be dangerous. Inspect flames after installation to ensure proper installation and performance.

If burner flame pattern differs from that described:

- turn fireplace off (see [To Turn Off Gas to Appliance](#), page 19)
- see [Troubleshooting](#), page 23

## SPECIFICATIONS

### LexingtonLights43ZEN

- Rating (Variable): 25/39,000 Btu/Hr
- Gas Type: Natural Gas
- Ignition: Piezo
- Pressure Manifold Setting: 3.5" W.C.
- Inlet Gas Pressure (in. of water):  
Maximum - 10.5" W.C.,  
Minimum\* - 5.5" W.C.

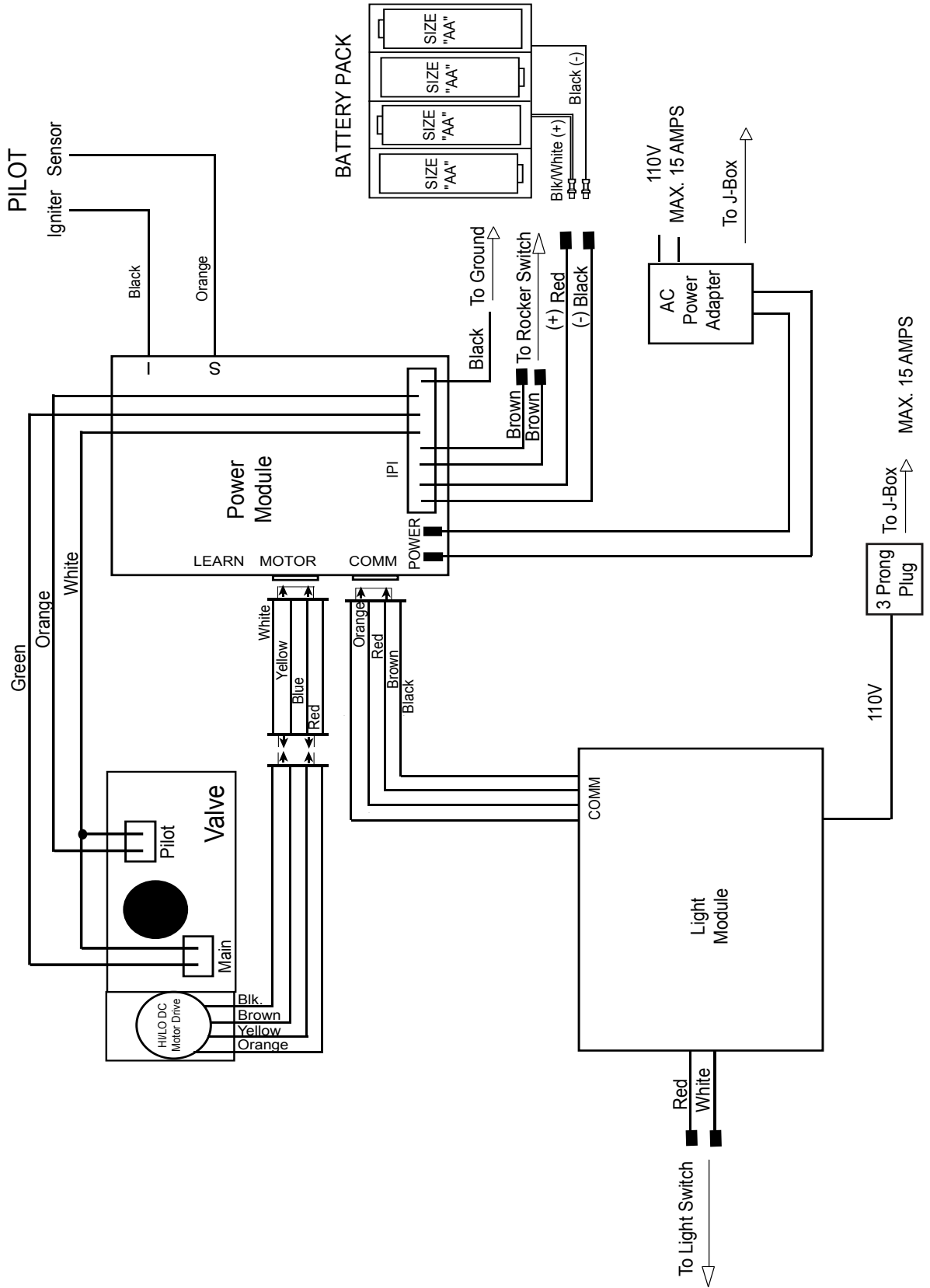
\* For purposes of input adjustment

### LexingtonLights43ZEP

- Rating (Variable): 29/37,000 Btu/Hr
- Gas Type: Propane/LP Gas
- Ignition: Piezo
- Pressure Manifold Setting: 10.5" W.C.
- Inlet Gas Pressure (in. of water):  
Maximum - 14" W.C.  
Minimum\* - 11" W.C.

\* For purposes of input adjustment

# WIRING DIAGRAM



## TROUBLESHOOTING

**⚠ WARNING: Turn off heater and let cool before servicing. Only a qualified service person should service and repair heater.**

**⚠ CAUTION: Never use a wire, needle or similar object to clean ODS/pilot. This can damage ODS/pilot unit.**

**Note:** All troubleshooting items are listed in order of operation.

OBSERVED PROBLEM	POSSIBLE CAUSE	REMEDY
When ignitor button is pressed, there is no spark at ODS/pilot	<ol style="list-style-type: none"> <li>1. Ignitor electrode not connected to ignitor cable</li> <li>2. Ignitor cable pinched or wet</li> <li>3. Broken ignitor cable</li> <li>4. Ignitor electrode positioned wrong</li> <li>5. Ignitor electrode broken</li> </ol>	<ol style="list-style-type: none"> <li>1. Reconnect ignitor cable</li> <li>2. Free ignitor cable if pinched by any metal or tubing. Keep ignitor cable dry</li> <li>3. Replace ignitor cable</li> <li>4. Replace pilot assembly</li> <li>5. Replace pilot assembly</li> </ol>
When ignitor button is pressed, there is spark at ODS/pilot but no ignition	<ol style="list-style-type: none"> <li>1. Gas supply turned off or equipment shutoff valve closed</li> <li>2. Depleted gas supply (propane/LP only)</li> <li>3. ODS/pilot is clogged</li> <li>4. Gas regulator setting is not correct</li> </ol>	<ol style="list-style-type: none"> <li>1. Turn on gas supply or open equipment shutoff valve</li> <li>2. Contact local propane/LP gas company</li> <li>3. Clean ODS/pilot (see <a href="#">Cleaning and Maintenance</a>, page 20) or replace ODS/pilot assembly</li> <li>4. Replace gas regulator</li> </ol>
Burner does not light after ODS/pilot is lit	<ol style="list-style-type: none"> <li>1. Inlet gas pressure is too low</li> <li>2. Burner orifice(s) clogged</li> <li>3. Thermopile leads disconnected or improperly connected</li> <li>4. Burner will not come on in remote position</li> </ol>	<ol style="list-style-type: none"> <li>1. Contact local natural or propane/LP gas company</li> <li>2. Clean burner(s) (see <a href="#">Cleaning and Maintenance</a>, page 20) or replace burner orifice(s)</li> <li>3. Reconnect leads (see <a href="#">Wiring Diagram</a>, page 22)</li> <li>4. Replace battery in transmitter and receiver</li> </ol>
Delayed ignition of one or both burners	<ol style="list-style-type: none"> <li>1. Manifold pressure is too low</li> <li>2. Burner orifice(s) clogged</li> </ol>	<ol style="list-style-type: none"> <li>1. Contact local natural or propane/LP gas company</li> <li>2. Clean burner(s) (see <a href="#">Cleaning and Maintenance</a>, page 20) or replace burner orifice(s)</li> </ol>

---

## TROUBLESHOOTING *Continued*

<b>OBSERVED PROBLEM</b>	<b>POSSIBLE CAUSE</b>	<b>REMEDY</b>
Slight smoke or odor during initial operation	1. Not enough air	1. Check burner for dirt and debris. If found, clean burner (see <a href="#">Cleaning and Maintenance</a> , page 20)
Heater produces a whistling noise when burners are lit	1. Not enough combustion/ventilation air	1. Refer to <a href="#">Air for Combustion and Ventilation</a> requirements (page 5)
	1. Pressing button to HI position when burners are cold	1. Press button to LO position and let warm up for a minute
	2. Air in gas line	2. Operate burners until air is removed from line. Have gas line checked by local natural or propane/LP gas company
	3. Air passageways on heater blocked	3. Observe minimum installation clearances (see page 7)
	4. Dirty or partially clogged burner orifice(s)	4. Clean burners (see <a href="#">Cleaning and Maintenance</a> , page 20) or replace burner orifice(s)
White powder residue forming within burner box or on adjacent walls or furniture	1. When heated, vapors from furniture polish, wax, carpet cleaners, etc. may turn into white powder residue	1. Turn heater off when using furniture polish, wax, carpet cleaners or similar products
Remote does not function	1. Battery is not installed. Battery power is low	1. Replace 4 AA batteries in receiver and 3 AAA batteries in hand-held remote control
	2. Wire connection loose or wire broken	2. Check wiring connections (see <a href="#">Wiring Diagram</a> , page 22). Replace wiring harness if necessary
Fireplace produces a clicking/ticking noise just after burner is lit or shut off	1. Metal expanding while heating or contracting while cooling	1. This is normal with most heaters. If noise is excessive, contact qualified service person
Burner backfiring during combustion	1. Burner orifice is clogged or damaged	1. Clean burner (see <a href="#">Cleaning and Maintenance</a> , page 20) or replace burner orifice(s)
	2. Damaged burner	2. Replace damaged burner



## TROUBLESHOOTING *Continued*

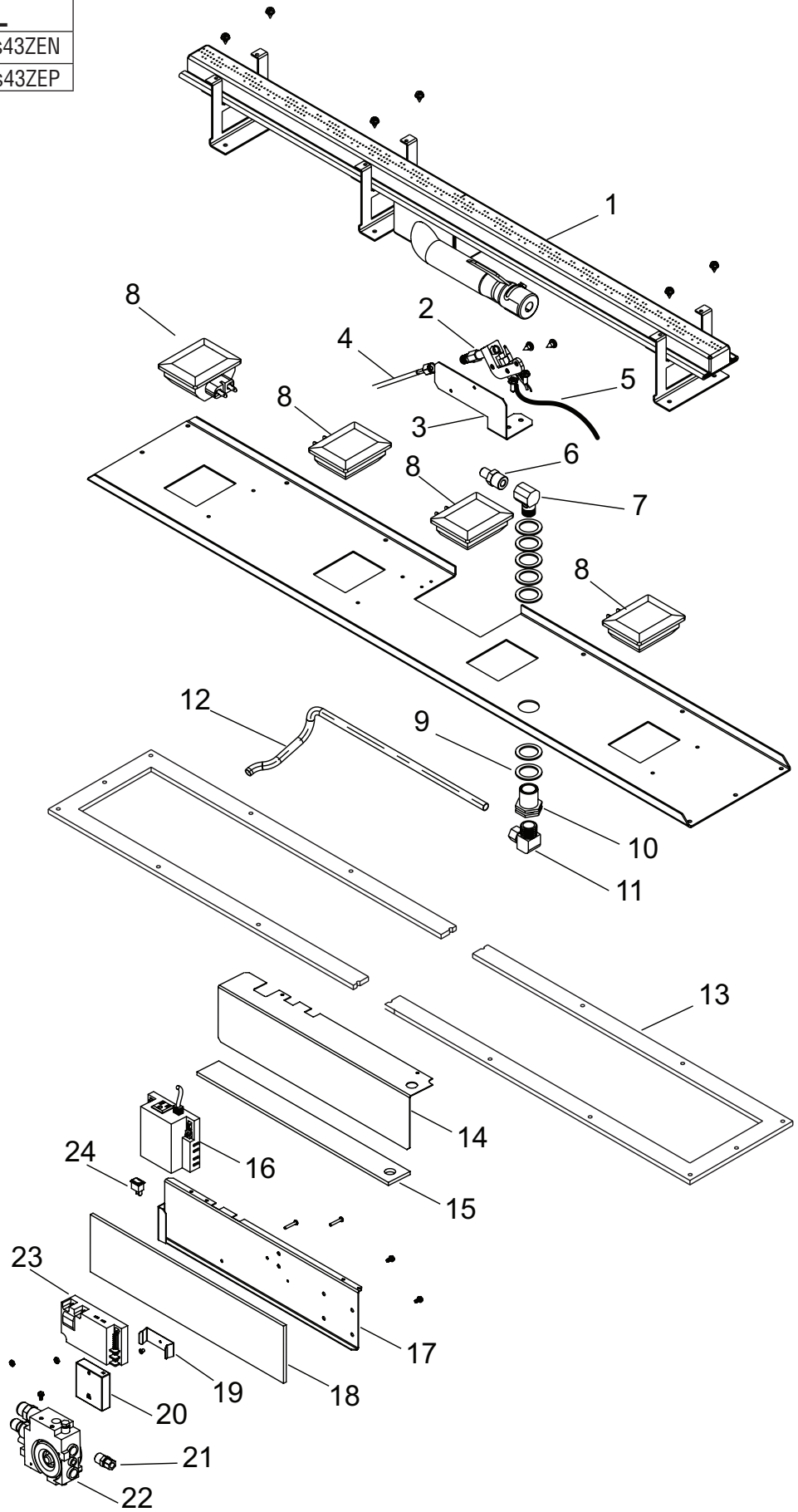
- ⚠ WARNING: If you smell gas**
- Shut off gas supply.
  - Do not try to light any appliance.
  - Do not touch any electrical switch; do not use any phone in your building.
  - Leave the building immediately
  - Immediately call your gas supplier from a neighbor's phone. Follow the gas supplier's instructions.
  - If you cannot reach your gas supplier, call the fire department.

**IMPORTANT:** Operating fireplace where impurities in air exist may create odors. Cleaning supplies, paint, paint remover, cigarette smoke, cements and glues, new carpet or textiles, etc., create fumes. These fumes may mix with combustion air and create odors. These odors will disappear over time.

OBSERVED PROBLEM	POSSIBLE CAUSE	REMEDY
Fireplace produces unwanted odors	<ol style="list-style-type: none"> <li>1. Heater burning vapors from paint, hair spray, glues, cleaners, chemicals, new carpet, etc. (<b>See IMPORTANT statement above</b>)</li> <li>2. Low fuel supply (propane/LP only)</li> <li>3. Gas leak. <b>See Warning statement above</b></li> </ol>	<ol style="list-style-type: none"> <li>1. Open window to ventilate room. Stop using odor causing products while heater is running</li> <li>2. Refill supply tank (propane/LP only)</li> <li>3. Locate and correct all leaks (see <a href="#">Checking Gas Connections</a>, page 12)</li> </ol>
Fireplace shuts off in use (ODS operates)	<ol style="list-style-type: none"> <li>1. Not enough fresh air is available</li> <li>2. Low line pressure</li> <li>3. ODS/pilot is partially clogged</li> </ol>	<ol style="list-style-type: none"> <li>1. Open window and/or door for ventilation</li> <li>2. Contact local natural or propane/LP gas company</li> <li>3. Clean ODS/pilot (see <a href="#">Cleaning and Maintenance</a>, page 20)</li> </ol>
Gas odor even when control button is in OFF position	<ol style="list-style-type: none"> <li>1. Gas leak. <b>See Warning statement above</b></li> <li>2. Control valve or gas control defective</li> </ol>	<ol style="list-style-type: none"> <li>1. Locate and correct all leaks (see <a href="#">Checking Gas Connections</a>, page 12)</li> <li>2. Replace control valve or gas control</li> </ol>
Gas odor during combustion	<ol style="list-style-type: none"> <li>1. Foreign matter between control valve and burner</li> <li>2. Gas leak. <b>See Warning statement above</b></li> </ol>	<ol style="list-style-type: none"> <li>1. Take apart gas tubing and remove foreign matter</li> <li>2. Locate and correct all leaks (see <a href="#">Checking Gas Connections</a>, page 12)</li> </ol>

# PARTS

CATALOG NO.	MODEL
F2508	LexingtonLights43ZEN
F2509	LexingtonLights43ZEP



## PARTS

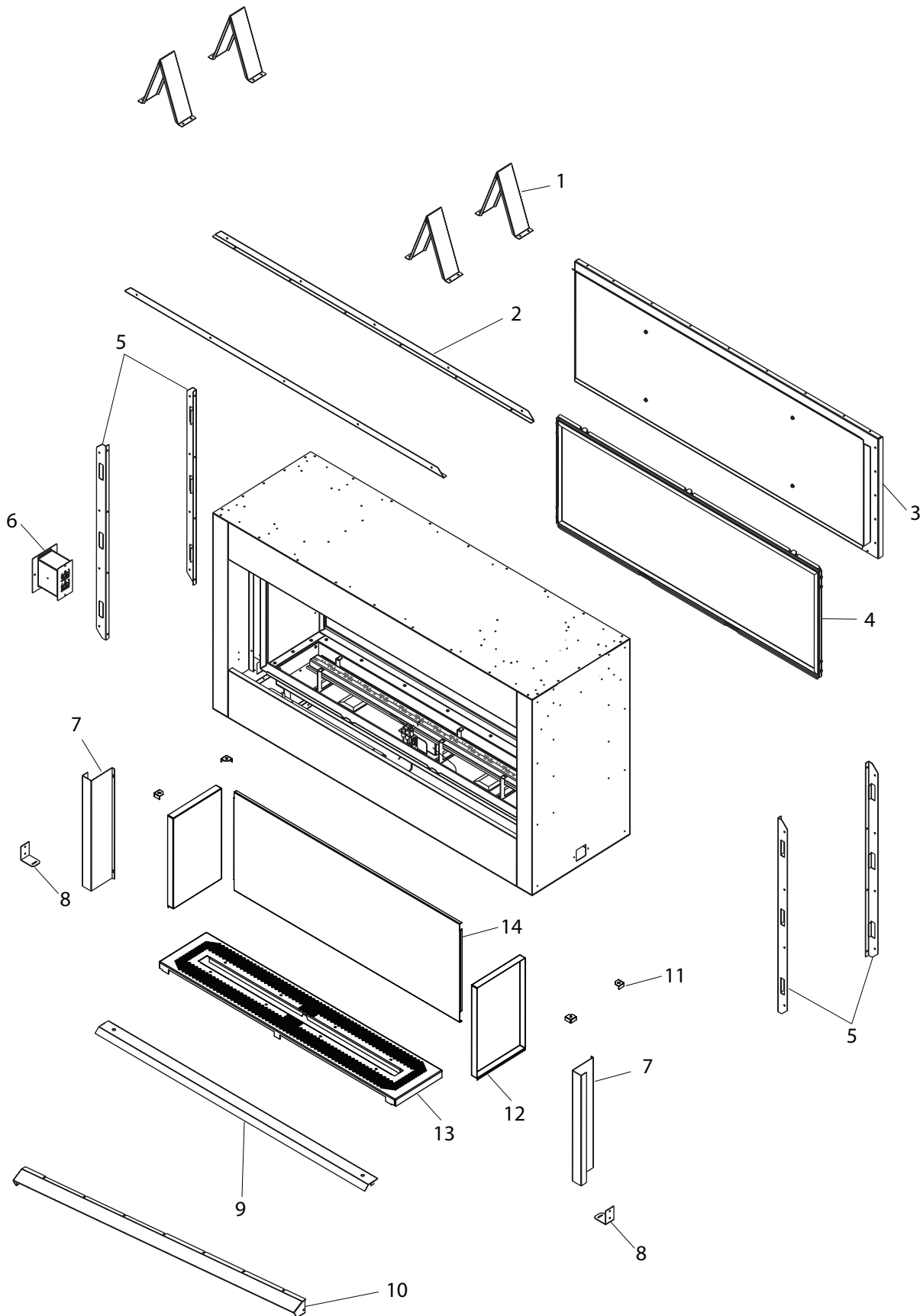
This list contains replaceable parts used in your fireplace. When ordering parts, follow the instructions listed under [Replacement Parts](#) on page 30 of this manual.

**⚠ WARNING: Contact an IHP dealer to obtain any of these parts. Never use substitute materials not approved by IHP. Use of non-approved parts can result in poor performance and safety hazards.**

KEY NO.	CATALOG NO.	DESCRIPTION	LexingtonLights43ZEN	LexingtonLights43ZEP	QTY.
			(F2508)	(F2509)	
1	J6564	Burner Assembly	•	•	1
2	J7947	Pilot, NG	•		1
	J8023	Pilot, LP		•	1
3	J7458	Bracket, Pilot	•	•	1
4	J3635	Tube, Pilot	•	•	1
5	J8031	Cable, Spark Wire	•	•	4
6	J7053	Orifice, #32	•		1
	J6989	Orifice, #49		•	1
7	J6819	Brass Elbow	•	•	1
8	J6757	Light Bulb, G9 120V/20W	•	•	4
9	J5207	Flat Washer	•	•	7
10	J4775	Bulkhead Fitting	•	•	1
11	J6834	Brass Elbow	•	•	2
12	J4714	Flextube, Dormont	•	•	1
13	J6694	Burner Gasket	•	•	2
14	J6737	Electronic Access Cover	•	•	1
15	J8032	Insulation, Heatshield	•	•	1
16	J6718	Module, Extension	•	•	1
17	J6570	Bracket Valve Components	•	•	1
18	J6738	Insulation, Heatshield	•	•	1
19	RP125072-03	Bracket, Battery Backup	•	•	1
20	J6205	Battery Backup	•	•	1
21	J6833	Connector, 3/8 Tube x 3/8 MPT	•	•	1
22	J8033	Valve, NG	•		1
	J8040	Valve, LP		•	1
23	J7939	Control Module Skytech AF4000MOD	•	•	1
24	J6868	Switch, Rocker ON/OFF Remote	•	•	1
<b>PARTS AVAILABLE NOT SHOWN</b>					
	J6725	Clear Pebbles (6 lbs)	•	•	1
	J6201	Wire Harness, AF-400008PIN24WH2	•	•	1
	J6717	Main Step Wire Harness	•	•	1
	J6719	Harness Ext. AF-4000COMM12WH	•	•	1
	J6795	Remote Transmitter	•	•	1
	J8041	30" Flex Line	•	•	1

# PARTS

CATALOG NO.	MODEL
F2508	LexingtonLights43ZEN
F2509	LexingtonLights43ZEP



## PARTS

### BURNER ASSEMBLY

This list contains replaceable parts used in your fireplace. When ordering parts, follow the instructions listed under [Replacement Parts](#) on page 30 of this manual.

**⚠ WARNING: Contact an IHP dealer to obtain any of these parts. Never use substitute materials not approved by IHP. Use of non-approved parts can result in poor performance and safety hazards.**

KEY			LexingtonLights43ZEN	LexingtonLights43ZEP	
NO.	CATALOG NO.	DESCRIPTION	(F2508)	(F2509)	QTY.
1	J6630	Top Spacer	•	•	4
2	J6566	Top Nailing Flange	•	•	2
3	J7644	Rear Panel	•	•	1
4	J7877	False Door Assembly	•	•	1
5	J7454	Side Nailing Flange	•	•	4
6	J4387	Electric Duct Assembly	•	•	1
7	J6572	Side Face Filler	•	•	2
8	J6574	Access Cover Retaining Bracket	•	•	2
9	J6576	Access Door	•	•	1
10	J6720	Fireplace Hood	•	•	2
11	J7885	Corner Bracket	•	•	4
12	J6596	Side Walls	•	•	2
13	J6565	Pebble Pan	•	•	1
14	J6597	Rear Wall	•	•	1

## SERVICE HINTS

When Gas Pressure Is Too Low

- pilot will not stay lit
- burner will have delayed ignition
- fireplace will not produce specified heat
- for propane/LP unit, propane/LP gas supply may be low

You may feel your gas pressure is too low. If so, contact your local gas supplier.

## TECHNICAL SERVICE

You may have further questions about installation, operation, or troubleshooting. Please contact your IHP dealer for any questions or concerns. When contacting your dealer please have your model and serial numbers of your fireplace ready. You can also visit our web site at [Comfortflame.us.com](http://Comfortflame.us.com)

## REPLACEMENT PARTS

See Pages 26 to 29 for a complete replacement parts list. Use only parts supplied from the manufacturer.

Normally, all parts should be ordered through your IHP distributor or dealer. Parts will be shipped at prevailing prices at time of order.

When ordering repair parts, always give the following information:

1. The model number of the fireplace.
2. The serial number of the fireplace.
3. The part number.
4. The description of the part.
5. The quantity required.
6. The installation date of the fireplace.

If you encounter any problems or have any questions concerning the installation or application of this fireplace, please contact your dealer.

### IHP

1769 East Lawrence Street  
Russellville, AL 35654  
Visit us at [Comfortflame.us.com](http://Comfortflame.us.com)

## ACCESSORIES

Purchase these fireplace accessories from your local dealer. If they can not supply these accessories, contact IHP at [Comfortflame.us.com](http://Comfortflame.us.com) for referral information.

CAT NO.	MODEL	DESCRIPTION
<b>LINEAR DECORATIVE SURROUND KITS</b>		
F4216	DS-BLK-43	Decorative Surround for 43" Linear Fireplace - Black
F4217	DS-AS-43	Decorative Surround for 43" Linear Fireplace - Aged Silver
F4218	DS-AC-43	Decorative Surround for 43" Linear Fireplace - Aged Copper
<b>LINEAR SEE-THRU CONVERSION KITS</b>		
F1030	LVSTI	Linear VF See-Thru Conversion Kit
F1029	LVSTO	Linear OD. VF See-Thru Conversion Kit
F1031	LV43DS	43" Linear VF Draft Shield Kit
<b>LINEAR BARRIER KIT</b>		
F2882	LVI43B	Linear 43 ID Barrier
<b>GLASS MEDIA</b>		
F1097	GP43A	6.0 lb. Bag Smooth Glass Pebbles - Amber
F1098	GP43B	6.0 lb. Bag Smooth Glass Pebbles - Blue
F1099	GP43G	6.0 lb. Bag Smooth Glass Pebbles - Green
F1101	GP43C	6.0 lb. Bag Clear Glass Pebbles

# Innovative Hearth Products Comfort Flame® Brand Gas Fireplace, Stove and Insert 20 Year Limited Warranty

## THE WARRANTY

Innovative Hearth Products ("IHP") 20 Year Limited Warranty warrants your Comfort Flame® Brand gas fireplace or insert ("Product") to be free from defects in materials and workmanship at the time of manufacture. The product body, firebox and barrier carry the 20 Year Limited Warranty. Ceramic glass carries the 20 Year Limited Warranty against thermal breakage only. After installation, if covered components manufactured by IHP are found to be defective in materials or workmanship during the 20 Year Limited Warranty period and while the Product remains at the site of the original installation, IHP will, at its option, repair or replace the covered components. If repair or replacement is not commercially practical, IHP will, at its option, refund the purchase price or wholesale price of the IHP product, whichever is applicable. IHP will also pay IHP prevailing labor rates, as determined in its sole discretion, incurred in repairing or replacing such components for up to five years. THERE ARE EXCLUSIONS AND LIMITATIONS to this 20 Year Limited Warranty as described herein.

## COVERAGE COMMENCEMENT DATE

Warranty coverage begins on the date of purchase. In the case of new home construction, warranty coverage begins on the date of first occupancy of the dwelling or six months after the sale of the Product by an independent IHP dealer/distributor, whichever occurs earlier. The warranty shall commence no later than 24 months following the date of product shipment from IHP, regardless of the installation or occupancy date.

## EXCLUSIONS AND LIMITATIONS

This 20 Year Limited Warranty applies only if the Product is installed in the United States or Canada and only if operated and maintained in accordance with the printed instructions accompanying the Product and in compliance with all applicable installation and building codes and good trade practices.

This warranty is non-transferable and extends to the original owner only. The Product must be purchased through a listed supplier of IHP and proof of purchase must be provided. The product body, firebox and barrier carry the 20 Year Limited Warranty from the date of installation. Vent components, trim components and paint are excluded from this 20 Year Limited Warranty. The following do not carry the 20 Year Limited Warranty but are warranted as follows:

- Burner** – Repair or replacement for one year from the date of installation
- Gas components** – Repair or replacement for one year from the date of installation
- Gaskets** – Repair or replacement for one year from the date of installation
- Gold & nickel plating** – Replacement for two years from date of installation. Excludes tarnishing
- Logs** – Replacement for one year from the date of installation against thermal breakage only
- Optional blowers & remote controls** – Repair or replacement for one year from the date of installation
- Optional glass doors** – Repair or replacement for 90 days from the date of installation
- Tempered glass** – Replacement for one year from the date of installation
- Labor coverage** – Prevailing IHP labor rates apply for the warranty period of the component

**Parts not otherwise listed carry a 90 day warranty from the date of installation.**

**Whenever practicable, IHP will provide replacement parts, if available, for a period of 10 years from the last date of manufacture of the Product.**

IHP will not be responsible for: (a) damages caused by normal wear and tear, accident, riot, fire, flood or acts of God; (b) damages caused by abuse, negligence, misuse, or unauthorized alteration or repair of the Product affecting its stability or performance (The Product must be subjected to normal use. The Product is designed to burn either natural or propane gas only. Burning conventional fuels such as wood, coal or any other solid fuel will cause damage to the Product, will produce excessive temperatures and could result in a fire hazard.); (c) damages caused by failing to provide proper maintenance and service in accordance with the instructions provided with the Product; (d) damages, repairs or inefficiency resulting from faulty installation or application of the Product.

IHP is not responsible for inadequate fireplace system draft caused by air conditioning and heating systems, mechanical ventilation systems, or general construction conditions which may generate negative pressure in the room in which the appliance is installed. Additionally IHP assumes no responsibility for drafting conditions caused by venting configurations, adjoining trees or buildings, adverse wind conditions or unusual environmental factors and conditions that affect the operation of the unit.

This 20 Year Limited Warranty covers only parts and labor as provided herein. In no case shall IHP be responsible for materials, components or construction, which are not manufactured or supplied by IHP or for the labor necessary to install, repair or remove such materials, components or construction. Additional utility bills incurred due to any malfunction or defect in equipment are not covered by this warranty. All replacement or repair components will be shipped F.O.B. from the nearest stocking IHP factory.

## LIMITATION ON LIABILITY

It is expressly agreed and understood that IHP's sole obligation and the purchaser's exclusive remedy under this warranty, under any other warranty, expressed or implied, or in contract, tort or otherwise, shall be limited to replacement, repair, or refund, as specified herein.

In no event shall IHP be liable for any incidental or consequential damages caused by defects in the Product, whether such damage occurs or is discovered before or after repair or replacement, and whether such damage is caused by IHP's negligence. IHP has not made and does not make any representation or warranty of fitness for a particular use or purpose, and there is no implied condition of fitness for a particular use or purpose.

IHP makes no expressed warranties except as stated in this 20 Year Limited Warranty. The duration of any implied warranty is limited to the duration of this expressed warranty.

No one is authorized to change this 20 Year Limited Warranty or to create for IHP any other obligation or liability in connection with the Product. Some states and provinces do not allow the exclusion or limitation of incidental or consequential damages, so the above limitations or exclusions may not apply to you. The provisions of this 20 Year Limited Warranty are in addition to and not a modification of or subtraction from any statutory warranties and other rights and remedies provided by law.

## INVESTIGATION OF CLAIMS AGAINST WARRANTY

IHP reserves the right to investigate any and all claims against this 20 Year Limited Warranty and to decide, in its sole discretion, upon the method of settlement.

To receive the benefits and advantages described in this 20 Year Limited Warranty, the appliance must be installed and repaired by a licensed contractor approved by IHP.

Contact IHP at the address provided herein to obtain a listing of approved dealers/distributors. **IHP shall in no event be responsible for any warranty work done by a contractor that is not approved without first obtaining IHP's prior written consent.**

## HOW TO REGISTER A CLAIM AGAINST WARRANTY

In order for any claim under this warranty to be valid, you must contact the IHP dealer/distributor from which you purchased the product. If you cannot locate the dealer/distributor, then you must notify IHP in writing. IHP must be notified of the claimed defect in writing within 90 days of the date of failure. Notices should be directed to the IHP Warranty Department at 1769 East Lawrence Street; Russellville, AL 35654 or visit our website at [WWW.COMFORTFLAME.US.COM](http://WWW.COMFORTFLAME.US.COM).

**Comfortflame.us.com**

Record the following important information about your fireplace:

Fireplace model number	
Fireplace serial number	
Date fireplace was Installed	
Type of gas fireplace uses	
Dealer name	



P900569-00

Innovative Hearth Products reserves the right to make changes at any time, without notice, in design, materials, specifications, prices and also to discontinue colors, styles and products. Consult your local distributor for fireplace code information.

Printed in U.S.A. © 2015 Innovative Hearth Products LLC

P/N 900569-00 Rev. F 10/2019



1769 East Lawrence Street • Russellville, AL 35654