



Installation and Operation Instructions Comfort Flame® Unvented (Vent-Free) Gas Stove Appliance Models:

NCBurnerZMN

NCBurnerZMP

P/N 900577-00 Rev NC 02/2016



Report No. 09-128

Remote-Ready Control Gas Log Appliance
(Burner System for Cast Iron stove)

IMPORTANT: This burner system must be installed into approved IHP cast iron stove body, model: Newcastle (F2510) only.

INSTALLER: Leave this manual with the appliance.
CONSUMER: Retain this manual for future reference.

This appliance may be installed in an aftermarket permanently located, manufactured (mobile) home, where not prohibited by local codes. This appliance is only for use with the type of gas indicated on the rating plate. This appliance is not convertible for use with other gases.

This is an un-vented gas-fired appliance. It uses air (oxygen) from the room in which it is installed. Provisions for adequate combustion and ventilation air must be provided. Refer to Air for Combustion and Ventilation section on page 5 of this manual.

⚠ WARNING: If the information in these instructions is not followed exactly, a fire or explosion may result causing property damage, personal injury or loss of life.

⚠ WARNING:
FIRE OR EXPLOSION HAZARD

Failure to follow safety warnings exactly could result in serious injury, death, or property damage.

- Do not store or use gasoline or other flammable vapors and liquids in the vicinity of this or any other appliance.
- **WHAT TO DO IF YOU SMELL GAS:**
 - Do not try to light any appliance.
 - Do not touch any electrical switch; do not use any phone in your building.
 - Leave the building immediately.
 - Immediately call your gas supplier from a neighbor's phone. Follow the gas supplier's instructions.
 - If you cannot reach your gas supplier, call the fire department.
- Installation and service must be performed by a qualified installer, service agency or the gas supplier.

Thank you for your purchase. We appreciate your business!

Please carefully read and follow all instructions in this manual. **Pay special attention to all warnings and safety information.**

Following these safety, care, and operation instructions will help ensure many years of dependable and enjoyable service from your appliance.

Please read and understand these instructions before installing or operating.



TABLE OF CONTENTS

Safety2
 Product Identification4
 Local Codes4
 Requirements for the Commonwealth of Massachusetts 4
 Product Features4
 Air for Combustion and Ventilation5
 Installation7
 Operation12
 Inspecting Burners13
 Cleaning and Maintenance14
 Troubleshooting15
 Wiring Diagram18
 Specifications18
 Service Hints18
 Technical Service18
 Replacement Parts18
 Accessories19
 Parts20
 Warranty23

SAFETY

⚠ WARNING: The NCBurnerZMN, NCBurnerZMP series vent-free gas log appliance is only approved for use in the Newcastle cast iron stove model.

⚠ WARNING: Improper installation, adjustment, alteration, service or maintenance can cause injury or property damage. Refer to this manual for correct installation and operational procedures. For assistance or additional information consult a qualified installer, service agency or the gas supplier.

⚠ WARNING: This is an unvented gas-fired appliance. It uses air (oxygen) from the room in which it is installed. Provisions for adequate combustion and ventilation air must be provided. Refer to Air for Combustion and Ventilation section on page 5 of this manual.

This appliance may be installed in an aftermarket, * permanently located, manufactured (mobile) home, where not prohibited by local codes.
This appliance is only for use with the type of gas indicated on the rating plate. This appliance is not convertible for use with other gases.

* Aftermarket: Completion of sale, not for purpose of resale, from the manufacturer

⚠ WARNING: This product contains and/or generates chemicals known to the state of California to cause cancer or birth defects or other reproductive harm.

IMPORTANT: Read this owner’s manual carefully and completely before trying to assemble, operate or service this appliance. Improper use of this appliance can cause serious injury or death from burns, fire, explosion, electrical shock and carbon monoxide poisoning.

⚠ DANGER: Carbon monoxide poisoning may lead to death!

Carbon Monoxide Poisoning: Early signs of carbon monoxide poisoning resemble the flu, with headaches, dizziness or nausea. If you have these signs, the appliance may not be working properly. Get fresh air at once! Have appliance serviced. Some people are more affected by carbon monoxide than others. These include pregnant women, people with heart or lung disease or anemia, those under the influence of alcohol and those at high altitudes.

Natural and Propane/LP Gas: Natural and propane/LP gases are odorless. An odor-making agent is added to the gas. The odor helps you detect a gas leak. However, the odor added to the gas can fade. Gas may be present even though no odor exists.

Make certain you read and understand all warnings. Keep this manual for reference. It is your guide to safe and proper operation of this appliance.

SAFETY *Continued*

⚠ WARNING: Any change to this appliance or its controls can be dangerous.

⚠ WARNING: Do not use a blower insert, heat exchanger insert or other accessory not approved for use with this appliance.

⚠ WARNING: Do not allow fans to blow directly into the appliance. Avoid any drafts that alter burner flame patterns. Ceiling fans can create drafts that alter burner flame patterns. Altered burner patterns can cause sooting.

Due to high temperatures, the appliance should be located out of traffic and away from furniture and draperies.

Do not place clothing or other flammable material on or near the appliance. Never place any objects on the appliance.

Stove becomes very hot when running appliance. Keep children and adults away from hot surface to avoid burns or clothing ignition. Appliance will remain hot for a time after shutdown. Allow surface to cool before touching.

Carefully supervise young children when they are in the room with stove. When using the optional hand-held remote accessory, keep selector switch in the OFF position to prevent children from turning on burners with remote.

Keep the appliance area clear and free from combustible materials, gasoline and other flammable vapors and liquids.

1. This appliance is only for use with the type of gas indicated on the rating plate. This appliance is not convertible for use with other gases.
2. Do not place propane/LP supply tank(s) inside any structure. Locate propane/LP supply tank(s) outdoors (propane/LP units only).
3. If you smell gas
 - shut off gas supply
 - do not try to light any appliance
 - do not touch any electrical switch; do not use any phone in your building
 - Leave the building immediately
 - immediately call your gas supplier from a neighbor's phone. Follow the gas supplier's instructions
 - if you cannot reach your gas supplier, call the fire department

4. This appliance shall not be installed in a bedroom or bathroom.
5. Do not use this stove as a wood burning fireplace. Use only model NCBurnerZMN-P series vent-free gas log appliance for Newcastle cast iron stove models.
6. Do not add extra logs or ornaments such as pine cones, vermiculite or rock wool. Using these added items can cause sooting.
7. This log appliance is designed to be smokeless. If logs ever appear to smoke, turn off appliance and call a qualified service person.
Note: During initial operation, slight smoking could occur due to log curing and appliance burning manufacturing residues.
8. To prevent the creation of soot, follow the instructions in [Cleaning and Maintenance](#), page 14.
9. Before using furniture polish, wax, carpet cleaners or similar products, turn appliance off. If heated, the vapors from these products may create a white powder residue within burner box or on adjacent walls or furniture.
10. This appliance needs fresh, outside air ventilation to run properly. This appliance has an Oxygen Depletion Sensing (ODS) safety shutoff system. The ODS shuts down the appliance if not enough fresh air is available. See [Air for Combustion and Ventilation](#), page 5. If appliance keeps shutting off, see [Troubleshooting](#), page 15.
11. Do not run appliance
 - where flammable liquids or vapors are used or stored
 - under dusty conditions
12. Do not use this stove to cook food or burn paper or other objects.
13. Do not use appliance if any part has been exposed to or under water. Immediately call a qualified service technician to inspect the room appliance and to replace any part of the control system and any gas control which has been under water.
14. Do not operate appliance if any log is broken. Do not operate appliance if a log is chipped (dime-sized or larger).
15. Turn appliance off and let cool before servicing. Only a qualified service person should service and repair appliance.
16. Operating appliance above elevations of 4,500 feet could cause pilot outage.
17. To prevent performance problems, the use of a propane/LP tank of less than 100 lb. capacity (propane/LP units only).
18. Provide adequate clearances around air openings.
19. Screen must be completely closed before using appliance. Never run appliance with screen open.

PRODUCT IDENTIFICATION

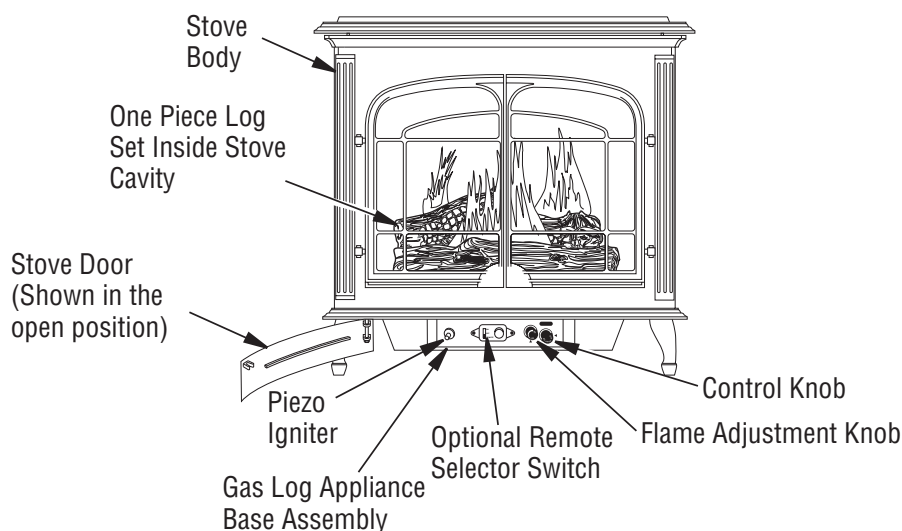

**Figure 1 - Typical Stove Cabinet with Gas Log Appliance
(Shown with Model NCBurnerZMN-P Appliance)**

LOCAL CODES

Install and use appliance with care. Follow all local codes. In the absence of local codes, use the latest edition of The National Fuel Gas Code ANSI Z223.1/NFPA 54*.

*Available from:

American National Standards Institute, Inc.
25 West 43rd Street, 4th floor
New York, NY 10036

National Fire Protection Association, Inc.
1 Batterymarch Park
Quincy, MA 02169-7471

State of Massachusetts: The installation must be made by a licensed plumber or gas fitter in the Commonwealth of Massachusetts. Sellers of unvented propane or natural gas-fired supplemental room appliances shall provide to each purchaser a copy of 527 CMR 30 upon sale of the unit.

Vent-free gas products are prohibited for bedroom and bathroom installation in the Commonwealth of Massachusetts.

COMMONWEALTH OF MASSACHUSETTS REQUIREMENTS

These appliances are approved for installation in the US state of Massachusetts if the following additional requirements are met:

- Un-vented Room Heaters shall be installed in accordance with 527 CMR 30.
- Installation and repair must be done by a plumber or gas fitter licensed in the Commonwealth of Massachusetts.
- The flexible gas line connector used shall not exceed 36 inches (92 centimeters) in length.
- The individual manual shut-off must be a T-handle type valve.
- Un-vented appliances may NOT be installed in bedrooms or bathrooms.
- A working smoke detector must be installed in the area where vent-free appliances are installed.

Seller of un-vented propane or natural gas-fired supplemental room heaters shall provide to each purchaser a copy of 527 CMR 30 upon sale of the unit.

PRODUCT FEATURES

OPERATION

This appliance is clean burning. It requires no outside venting. There is no heat loss out a vent or up a chimney. Heat is generated by realistic, dancing yellow flames. This appliance is designed for vent-free operation. State and local codes in some areas prohibit the use of vent-free appliances.

SAFETY PILOT

This appliance has a pilot with an Oxygen Depletion Sensing (ODS) safety shutoff system. The ODS/pilot is a required feature for vent-free room appliances. The ODS/pilot shuts off the appliance if there is not enough fresh air.

PIEZO IGNITION SYSTEM

This appliance has a piezo Igniter. This system requires no matches, batteries or other sources to light appliance.

AIR FOR COMBUSTION AND VENTILATION

⚠ WARNING: This appliance shall not be installed in a room or space unless the required volume of indoor combustion air is provided by the method described in the National Fuel Gas Code, ANSI Z223.1/NFPA 54, the International Fuel Gas Code, or applicable local codes. Read the following instructions to ensure proper fresh air for this and other fuel-burning appliances in your home.

Today's homes are built more energy efficient than ever. New materials, increased insulation and new construction methods help reduce heat loss in homes. Homeowners apply weather strip and caulk around windows and doors to keep the cold air out and the warm air in. During heating months, homeowners want their homes as airtight as possible.

While it is good to make your home energy efficient, your home needs to breathe. Fresh air must enter your home. All fuel-burning appliances need fresh air for proper combustion and ventilation.

Exhaust fans, some fireplaces, clothes dryers and some fuel-burning appliances draw air from the house to operate. You must provide adequate fresh air for these appliances. That will ensure proper venting of vented fuel-burning appliances.

PROVIDING ADEQUATE VENTILATION

The following are excerpts from National Fuel Gas Code, ANSI Z223.1/NFPA 54, Air for Combustion and Ventilation.

All spaces in homes fall into one of the three following ventilation classifications:

1. Unusually Tight Construction
2. Unconfined Space
3. Confined Space

The information on pages 5 through 6 will help you classify your space and provide adequate ventilation.

Unusually Tight Construction

The air that leaks around doors and windows may provide enough fresh air for combustion and ventilation. However, in buildings of unusually tight construction, you must provide additional fresh air.

Unusually tight construction is defined as construction where:

- a. walls and ceilings exposed to the outside atmosphere have a continuous water vapor retarder with a rating of one perm (6×10^{-11} kg per pa-sec- m^2) or less with openings gasketed or sealed and**
- b. weather stripping has been added on openable windows and doors and**
- c. caulking or sealants are applied to areas such as joints around window and door frames, between sole plates and floors, between wall-ceiling joints, between wall panels, at penetrations for plumbing, electrical and gas lines and at other openings.**

If your home meets all of these three criteria, you must provide additional fresh air. See [Ventilation Air From Outdoors](#), page 6.

If your home does not meet all of the three criteria above, proceed to [Determining Fresh-Air Flow For Fireplace Location](#).

Confined and Unconfined Space

The National Fuel Gas Code, ANSI Z223.1/NFPA54 allows two methods for determining whether the space in which the heater is being installed is confined or unconfined space. The standard method defines a confined space as a space whose volume is less than 50 cubic feet per 1,000 Btu/hr (4.8 m³ per kw) of the aggregate input rating of all appliances installed in that space and an unconfined space as a space whose volume is not less than 50 cubic feet per 1,000 Btu/hr (4.8 m³ per kw) of the aggregate input rating of all appliances installed in that space. Rooms communicating directly with the space in which the appliances are installed*, through openings not furnished with doors, are considered a part of the unconfined space.

Where the air infiltration rate of a structure is known, the Known Air Infiltration Rate Method may be used. Follow The National Fuel Gas Code, ANSI Z223.1/NFPA 54 to use this method to determine if the space is confined or unconfined.

* Adjoining rooms are communicating only if there are doorless passageways or ventilation grills between them.

DETERMINING FRESH-AIR FLOW FOR APPLIANCE LOCATION

Determining if You Have a Confined or Unconfined Space Using the Standard Method

Use this work sheet to determine if you have a confined or unconfined space.

Space: Includes the room in which you will install appliance plus any adjoining rooms with doorless passageways or ventilation grills between the rooms.

1. Determine the volume of the space (length x width x height).
Length x Width x Height = _____ cu. ft. (volume of space)
Example: Space size 20 ft. (length) x 16 ft. (width) x 8 ft. (ceiling height) = 2560 cu. ft. (volume of space)
If additional ventilation to adjoining room is supplied with grills or openings, add the volume of these rooms to the total volume of the space.
2. Multiply the space volume by 20 to determine the maximum Btu/Hr the space can support.
_____ (volume of space) x 20 = (Maximum Btu/Hr the space can support)
Example: 2560 cu. ft. (volume of space) x 20 = 51,200 (maximum Btu/Hr the space can support)
3. Add the Btu/Hr of all fuel burning appliances in the space.

Vent-free appliance	_____ Btu/Hr
Gas water appliance*	_____ Btu/Hr
Gas furnace	_____ Btu/Hr
Vented gas appliance	_____ Btu/Hr
Gas appliance logs	_____ Btu/Hr
Other gas appliances* +	_____ Btu/Hr
Total	= _____ Btu/Hr

* Do not include direct-vent gas appliances. Direct-vent draws combustion air from the outdoors and vents to the outdoors.

Example:

Gas water appliance	40,000 Btu/Hr
Vent-free fireplace	+ 30,000 Btu/Hr
Total	= 70,000 Btu/Hr

AIR FOR COMBUSTION AND VENTILATION *Continued*

4. Compare the maximum Btu/Hr the space can support with the actual amount of Btu/Hr used.

_____ Btu/Hr (maximum the space can support)

_____ Btu/Hr (actual amount of Btu/Hr used)

Example: 51,200 Btu/Hr (maximum the space can support)

70,000 Btu/Hr (actual amount of Btu/Hr used)

The space in the above example is a confined space because the actual Btu/Hr used is more than the maximum Btu/Hr the space can support. You must provide additional fresh air. Your options are as follows:

A. Rework worksheet, adding the space of an adjoining room. If the extra space provides an unconfined space, remove door to adjoining room or add ventilation grills between rooms. See Ventilation Air From Inside Building.

B. Vent room directly to the outdoors. See Ventilation Air From Outdoors.

C. Install a lower Btu/Hr appliance, if lower Btu/Hr size makes room unconfined.

If the actual Btu/Hr used is less than the maximum Btu/Hr the space can support, the space is an unconfined space. You will need no additional fresh air ventilation.

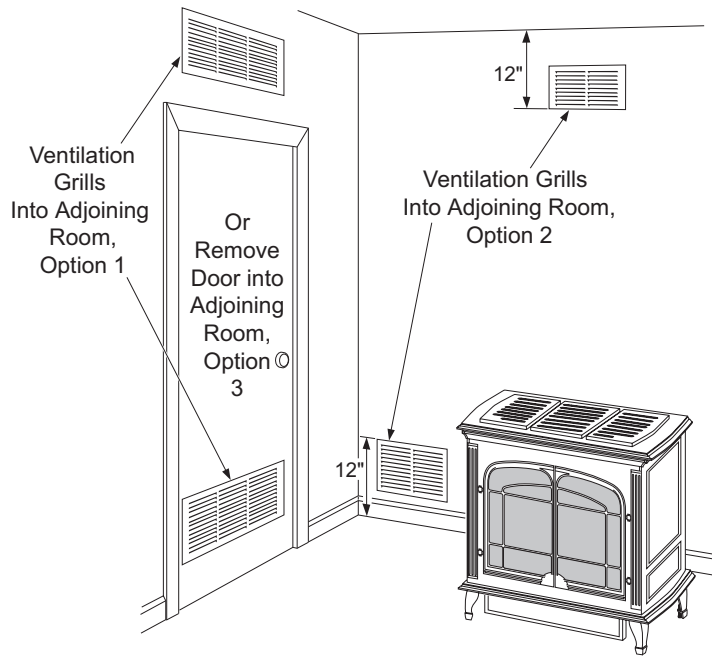

Figure 2 - Ventilation Air from Inside Building (Stove Model Shown)

⚠ WARNING: If the area in which the appliance may be operated does not meet the required volume for indoor combustion air, combustion and ventilation air shall be provided by one of the methods described in the National Fuel Gas Code, ANSI Z223.1/NFPA 54, the International Fuel Gas Code, or applicable local codes.

VENTILATION AIR

Ventilation Air From Inside Building

This fresh air would come from an adjoining unconfined space. When ventilating to an adjoining unconfined space, you must provide two permanent openings: one within 12" of the ceiling and one within 12" of the floor on the wall connecting the two spaces (see options 1 and 2, Figure 2). You can also remove door into adjoining room (see option 3, Figure 2). Follow the National Fuel Gas Code, ANSI Z223.1/NFPA 54, Air for Combustion and Ventilation for required size of ventilation grills or ducts.

Ventilation Air From Outdoors

Provide extra fresh air by using ventilation grills or ducts. You must provide two permanent openings: one within 12" of the ceiling and one within 12" of the floor. Connect these items directly to the outdoors or spaces open to the outdoors. These spaces include attics and crawl spaces. Follow the National Fuel Gas Code, ANSI Z223.1/NFPA 54, Air for Combustion and Ventilation for required size of ventilation grills or ducts.

IMPORTANT: Do not provide openings for inlet or outlet air into attic if attic has a thermostat-controlled power vent. Heated air entering the attic will activate the power vent.

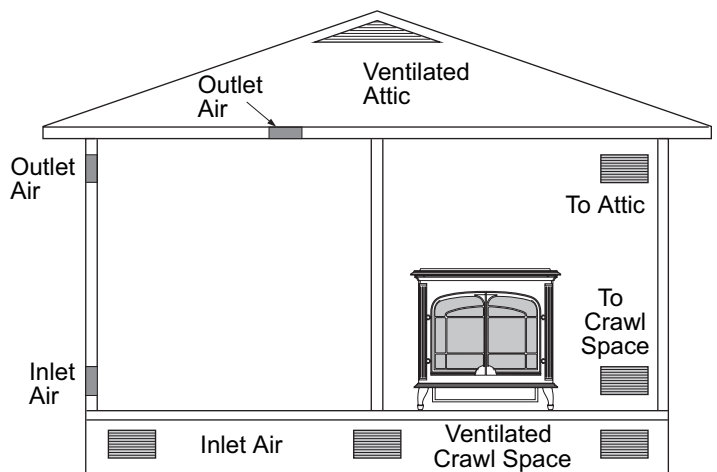

Figure 3 - Ventilation Air from Outdoors (Stove Model Shown)

INSTALLATION

NOTICE: This appliance is intended for use as supplemental heat. Use this appliance along with your primary heating system. Do not install this appliance as your primary heat source. If you have a central heating system, you may run system's circulating blower while using appliance. This will help circulate the heat throughout the house. In the event of a power outage, you can use this appliance as your primary heat source.

WARNING: A qualified service person must install appliance. Follow all local codes.

WARNING: Never install the appliance

- in a bedroom or bathroom
- in a recreational vehicle
- where curtains, furniture, clothing or other flammable objects are less than 42" from the front, top or sides of the appliance
- in high traffic areas
- in windy or drafty areas

CAUTION: This appliance creates warm air currents. These currents move heat to wall surfaces next to appliance. Installing appliance next to vinyl or cloth wall coverings or operating appliance where impurities (such as, but not limited to, tobacco smoke, aromatic candles, cleaning fluids, oil or kerosene lamps, etc.) in the air exist, may discolor walls or cause odors.

IMPORTANT: Vent-free appliances add moisture to the air. Although this is beneficial, installing appliance in rooms without enough ventilation air may cause mildew to form from too much moisture. See *Air for Combustion and Ventilation*, page 5.

CHECK GAS TYPE

Use only the correct type of gas (natural or propane/LP). If your gas supply is not the correct gas type, do not install appliance. Call dealer where you purchased appliance for proper type appliance.

WARNING: This appliance is equipped for either natural gas or propane/LP gas but not both. Gas type is indicated on the rating plate. Field conversion is not permitted.

CLEARANCES TO COMBUSTIBLES

WARNING: Maintain the minimum clearances. If you can, provide greater clearances from floor, ceiling and adjoining side and back walls.

Carefully follow the instructions below. This stove is a freestanding unit designed to set directly on the floor. **IMPORTANT:** You must maintain minimum wall and ceiling clearances during installation. The minimum clearances are shown in Figure 4. Measure from outermost point of stove top.

Minimum Wall and Ceiling Clearances (see Figure 4)

- Clearances from outermost point of stove top to any combustible side wall should not be less than 12".
- Clearances from outermost point of stove top to any combustible back wall should not be less than 6" (includes corner installations).
- Clearances from the stove top to the ceiling should not be less than 48".

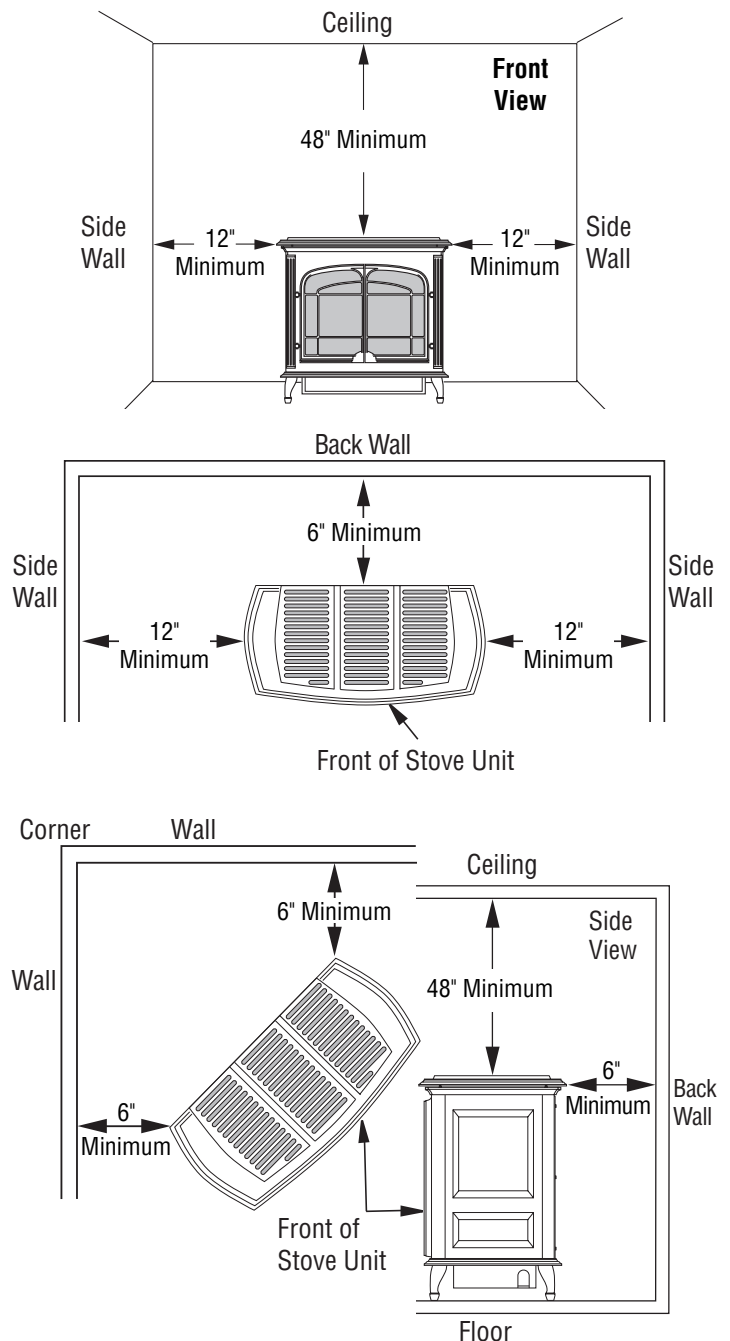

Figure 4 - Minimum Clearance to Walls and Ceiling (Stove May Vary Depending on Model)

INSTALLATION *Continued*

UNPACKING

1. Lift off corrugated box enclosing stove body crating.
2. Remove screws fastening back and top of wood frame enclosure. Two or more people must carefully lift stove up and out of wooden crate.
3. Remove plastic bag from stove body.
4. Remove back panel from stove (see Figure 5). Use an adjustable wrench or a 10 mm socket. Remove 4 bolts and washers. Keep bolts and washers to reattach back panel later.
5. Remove bubble-wrapped log set, rod and screen from stove. Remove all protective packaging applied for shipment.
6. Check appliance for any shipping damage. If appliance is damaged contact your IHP dealer for replacement parts before returning to dealer. Some fiber flakes may fall from logs. This is acceptable.
7. Place freestanding stove near desired location in room.

INSTALLING GAS LOG INTO STOVE

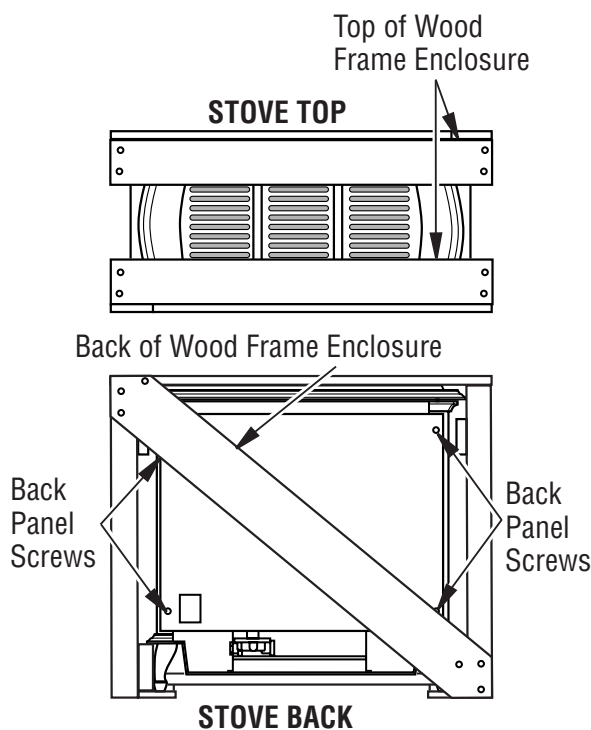

Figure 5 - Unpacking Stove from Wooden Shipping Enclosure

CAUTION: Do not remove the data plates attached to the appliance base assembly. The data plates contain important warranty and safety information.

WARNING: Failure to position the parts in accordance with these diagrams or failure to use only parts specifically approved with this appliance may result in property damage or personal injury.

1. Remove log from carton.
2. Remove all protective packaging applied to log for shipment.

3. Check log for any shipping damage. If damaged (pieces larger than the size of a dime), promptly inform dealer where you purchased appliance.
4. Set one-piece log on appliance base as shown in Figure 6. Make sure middle section at bottom of log is seated into "U" shaped cutout in center of appliance base. Log will fit securely on base. **IMPORTANT:** Make sure log does not cover any burner ports and does not touch the stove cavity (see Figure 7).
5. Fasten back panel to stove with four M6 x 1 bolts and washers.
6. Place freestanding stove in desired position in room. Be sure to maintain clearances to combustibles as outlined on page 7.

CAUTION: After installation and periodically thereafter, check to ensure that no flame comes in contact with any log. With the appliance set to HI, check to see if flames contact any log. If so, reposition logs according to the log installation instructions in this manual. Flames contacting logs will create soot.

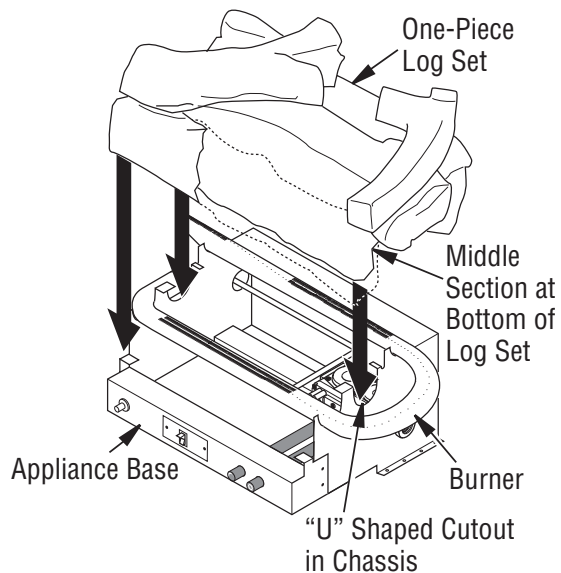

Figure 6 - Installing One-Piece Stove Log Set

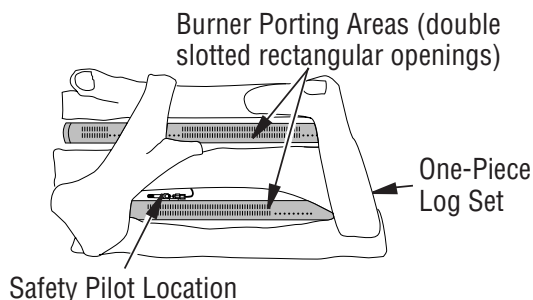

Figure 7 - Top View of One-Piece Log Set on Gas Log Appliance

INSTALLATION *Continued*

CONNECTING TO GAS SUPPLY

⚠ WARNING: This appliance requires a 3/8" NPT (National Pipe Thread) inlet connection to the pressure regulator.

⚠ WARNING: A qualified service person must connect appliance to gas supply. Follow all local codes.

⚠ CAUTION: Never connect propane/LP appliance directly to the propane/LP supply. This appliance requires an external regulator (not supplied). Install the external regulator between the appliance and propane/LP supply.

⚠ WARNING: Never connect natural gas appliance to private (non-utility) gas wells. This gas is commonly known as wellhead gas.

Installation Items Needed

Before installing appliance, make sure you have the items listed below.

- external regulator - propane/LP only (supplied by installer)
- piping (check local codes)
- sealant (resistant to propane/LP gas)
- equipment shutoff valve *
- test gauge connection *
- sediment trap
- tee joint
- pipe wrench

* A equipment shutoff valve with 1/8" NPT tap is an acceptable alternative to test gauge connection. Purchase the optional equipment shutoff valve from your dealer.

The gas inlet connection for the stove appliance is located on the lower right-hand side of stove when viewed from the front of unit. The gas connection can be made either through the bottom right side or through the lower back opening as illustrated in Figure 8. Make sure gas log appliance is secured to stove cavity assembly.

For propane/LP units, installer must supply an external regulator. The external regulator will reduce incoming gas pressure. You must reduce incoming gas pressure to between 11" and 14" of water. If you do not reduce incoming gas pressure, appliance regulator damage could occur. Install external regulator with the vent pointing down as shown in Figure 9. Pointing the vent down protects it from freezing rain or sleet.

⚠ CAUTION: Use only new, black iron or steel pipe. Internally-tinned copper tubing may be used in certain areas. Check your local codes. Use pipe of 1/2" diameter or greater to allow proper gas volume to appliance. If pipe is too small, undue loss of volume will occur.

Installation must include a equipment shutoff valve, union and plugged 1/8" NPT tap. Locate NPT tap within reach for test gauge hook up. NPT tap must be upstream from appliance (see Figure 10, page 12).

IMPORTANT: Install equipment shutoff valve in an accessible location. The equipment shutoff valve is for turning on or shutting off the gas to the appliances.

Check your building codes for any special requirements for locating equipment shutoff valve to appliances.

Apply pipe joint sealant lightly to male threads. This will prevent excess sealant from going into pipe. Excess sealant in pipe could result in clogged appliance valves.

⚠ WARNING: Use pipe joint sealant that is resistant to liquid petroleum (LP) gas.

We recommend that you install a sediment trap in supply line as shown in Figure 10, page 12. Locate sediment trap where it is within reach for cleaning. Install in piping system between fuel supply and appliance. Locate sediment trap where trapped matter is not likely to freeze. A sediment trap traps moisture and contaminants. This keeps them from going into appliance controls. If sediment trap is not installed or is installed wrong, appliance may not run properly.

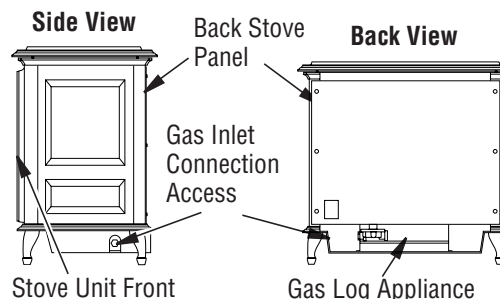

Figure 8 - Gas Regulator Location and Gas Line Access Into Stove Cabinet

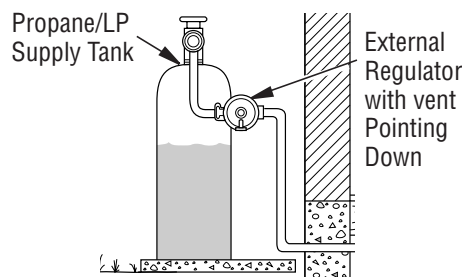
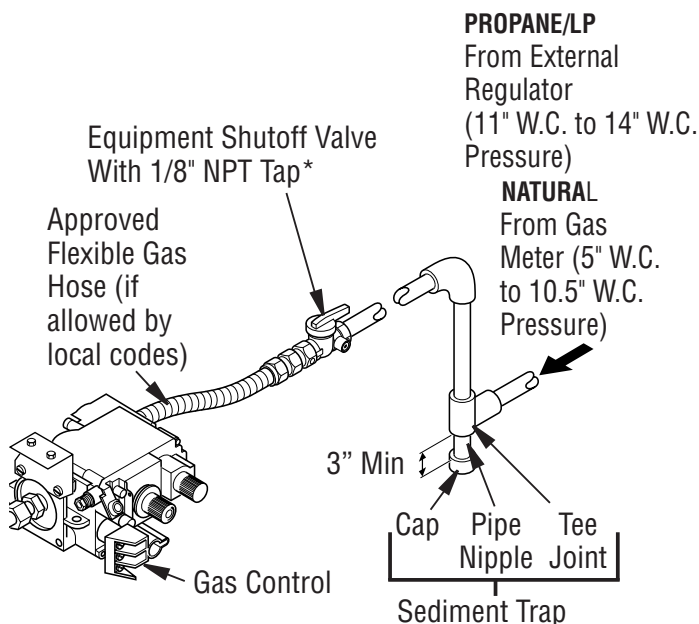

Figure 9 - External Regulator With Vent Pointing Down

INSTALLATION *Continued*

⚠ CAUTION: Avoid damage to regulator. Hold gas regulator with wrench when connecting it to gas piping and/or fittings.



* Purchase the optional equipment shutoff valve from your dealer.

** Minimum inlet pressure for purpose of input adjustment.

Figure 10 - Gas Connection (NCBurnerZMN-P Series)

CHECKING GAS CONNECTIONS

⚠ WARNING: Test all gas piping and connections, internal and external to unit, for leaks after installing or servicing. Correct all leaks at once.

⚠ WARNING: Never use an open flame to check for a leak. Apply a noncorrosive leak detection fluid to all joints. Bubbles forming show a leak. Correct all leaks at once.

⚠ CAUTION: Make sure external regulator has been installed between propane/LP supply and appliance. See guidelines under Connecting to Gas Supply, page 9.

PRESSURE TESTING GAS SUPPLY PIPING SYSTEM

Test Pressures In Excess Of 1/2 PSIG (3.5 kPa)

1. Disconnect appliance with its appliance main gas valve (control valve) and equipment shutoff valve from gas supply piping system. Pressures in excess of 1/2 psig will damage appliance regulator.
2. Cap off open end of gas pipe where equipment shutoff valve was connected.
3. Pressurize supply piping system by either opening propane/LP supply tank valve for propane/LP gas or opening main gas valve located on or near gas meter for natural gas or using compressed air.
4. Check all joints of gas supply piping system. Apply a noncorrosive leak detection fluid to gas joints. Bubbles forming show a leak.
5. Correct all leaks at once.
6. Reconnect appliance and equipment shutoff valve to gas supply. Check reconnected fittings for leaks.

Test Pressures Equal To or Less Than 1/2 PSIG (3.5 kPa)

1. Close equipment shutoff valve (see Figure 11).
2. Pressurize supply piping system by either opening propane/LP supply tank valve for propane/LP gas or opening main gas valve located on or near gas meter for natural gas or using compressed air.
3. Check all joints from gas meter for natural or propane/LP supply to equipment shutoff valve (see Figure 12 or 13, page 11). Apply a noncorrosive leak detection fluid to gas joints. Bubbles forming show a leak.
4. Correct all leaks at once.

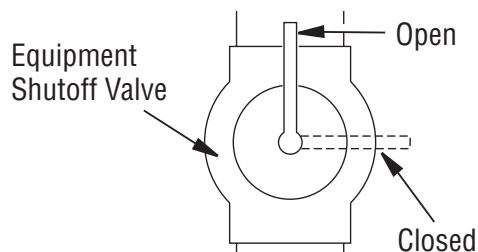

Figure 11 - Equipment Shutoff Valve

INSTALLATION *Continued*

PRESSURE TESTING APPLIANCE GAS CONNECTIONS

1. Open equipment shutoff valve (see Figure 11, page 10).
2. Open main gas valve located on or near gas meter for natural gas or open propane/LP supply tank valve.
3. Make sure control knob of appliance is in the OFF position.
4. Check all joints from equipment shutoff valve to control valve (see Figure 12 or 13). Apply a noncorrosive leak detection fluid to gas joints. Bubbles forming show a leak.
5. Correct all leaks at once.
6. Light appliance (see Operation, page 12). Check all other internal joints for leaks.
7. Turn off appliance (see To Turn Off Gas to Appliance, page 13).

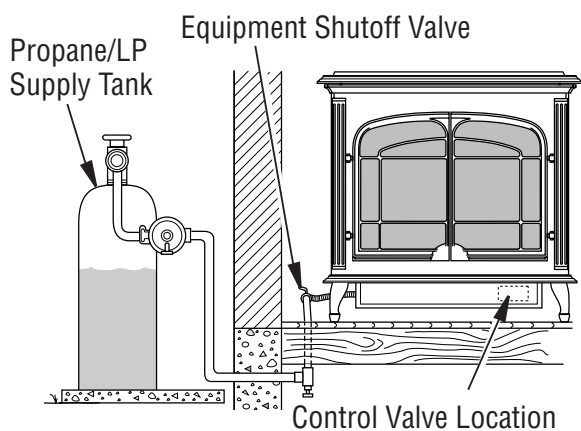

Figure 12 - Checking Gas Joints (Stove Model Shown)

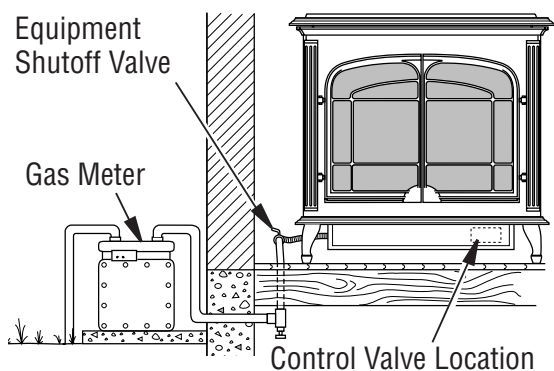

Figure 13 - Checking Gas Joints Stove Model Shown)

INSTALLING ROD AND SCREEN

1. Insert rod through small rings located at top of screen (see Figure 14).
2. From back of stove, insert rod into hole located inside right front of stove as shown in Figure 15.
3. Slip left side of rod down into slot on inside left front of stove (see Figure 15).

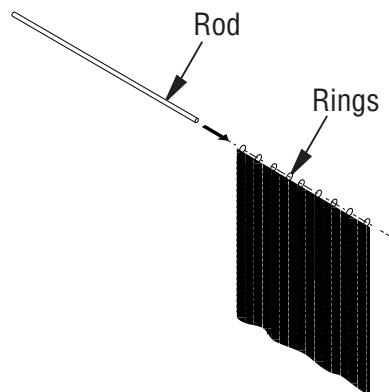

Figure 14 - Assembling Rod and Screen

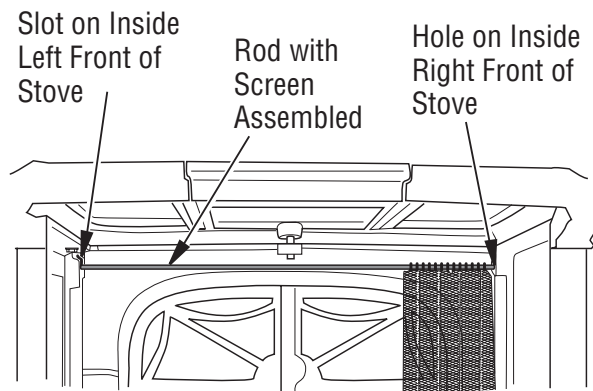

Figure 15 - Installing Screen Into Stove (View From Back of Stove)

OPERATION

FOR YOUR SAFETY READ BEFORE LIGHTING

⚠ WARNING: If you do not follow these instructions exactly, a fire or explosion may result causing property damage, personal injury or loss of life.

- This appliance has a pilot which must be lighted by hand. When lighting the pilot, follow these instructions exactly.
- BEFORE LIGHTING** smell all around the appliance area for gas. Be sure to smell next to the floor because some gas is heavier than air and will settle on the floor.
WHAT TO DO IF YOU SMELL GAS
 - Do not try to light any appliance.
 - Do not touch any electric switch; do not use any phone in your building.
 - Leave the building immediately
 - Immediately call your gas supplier from a neighbor's phone. Follow the gas supplier's instructions.
 - If you cannot reach your gas supplier, call the fire department.
- Use only your hand to push in or turn the gas control knob. Never use tools. If the knob will not push in or turn by hand, don't try to repair it, call a qualified service technician or gas supplier. Force or attempted repair may result in a fire or explosion.
- Do not use this appliance if any part has been under water. Immediately call a qualified service technician to inspect the appliance and to replace any part of the control system and any gas control which has been under water.

LIGHTING INSTRUCTIONS

NOTICE: During initial operation of new appliance, burning logs will give off a paper-burning smell. Open window to vent smell. This will only last a few hours.

- STOP! Read the safety information above.
- Make sure equipment shutoff valve is fully open.
- Set switch to OFF position.

⚠ WARNING: Burners will come on automatically within one minute when the remote selector switch is in the ON position after the pilot is lit.

- Press in and turn control knob clockwise ↻ to the OFF position.
- Wait five (5) minutes to clear out any gas. Then smell for gas, including near the floor. If you smell gas, STOP! Follow "B" in the safety information. If you don't smell gas, go to the next step.
- Press in and turn control knob counterclockwise ↻ to the PILOT position. Press in control knob for five (5) seconds (see step 5).

Note: You may be running this appliance for the first time after hooking up to gas supply. If so, the control knob may need to be pressed in for 30 seconds or more. This will allow air to bleed from the gas system.

- With control knob pressed in, press and release Igniter button. This will light pilot. The pilot is attached to the front burner (see Figure 7, page 8). If needed, keep pressing Igniter button until pilot lights.
Note: If pilot does not stay lit, contact a qualified service person or gas supplier for repairs. Until repairs are made, light pilot with match. To light pilot with match, see Manual Lighting Procedure, page 13.
- Keep control knob pressed in for 30 seconds after lighting pilot. After 30 seconds, release control knob.
 - If control knob does not pop out when released, contact a qualified service person or gas supplier for repairs.**Note:** If pilot goes out, repeat steps 4 through 8.
- Slightly push in and turn control knob counterclockwise ↻ to the ON position.
- Wait one minute and switch remote selector switch to the ON position to light burners. **Note:** AUTO is only functional when using GWMT1 or GWMS2 optional accessories.
- Set flame adjustment knob to any level between HI and LO.
- To leave pilot lit and shut off burners only, turn control knob clockwise ↻ to the PILOT position.

⚠ CAUTION: Do not try to adjust heating levels by using the equipment shutoff valve.

⚠ WARNING: Make sure the selector switch is in the OFF position when you are away from home for long periods of time. Appliance will come on automatically with selector switch in the ON position.

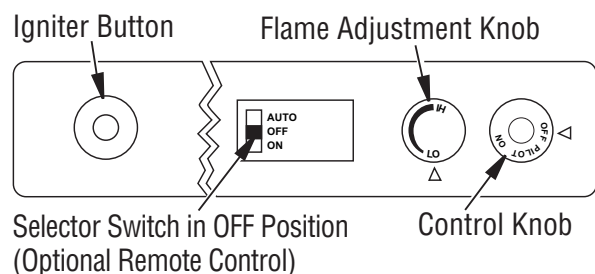

Figure 16 - Control Knob and Igniter Button Location (Shown as Supplied, No Control Options)

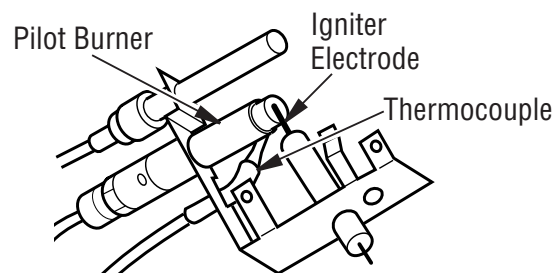



Figure 17 - Pilot

OPERATION *Continued*

TO TURN OFF GAS TO APPLIANCE

Shutting Off Appliance

1. Turn control knob clockwise  to the OFF position.
2. Set selector switch in the OFF position to keep from draining battery.
3. Close equipment shutoff valve (see Figure 11, page 10).

MANUAL LIGHTING PROCEDURE

1. Follow steps 1 through 6 under Lighting Instructions, page 12.
2. Press control knob and light pilot with match.
3. Keep control knob pressed in for 30 seconds after lighting pilot. After 30 seconds, release control knob. Now follow steps 9 through 11 under Lighting Instructions, page 12.

OPTIONAL HAND-HELD REMOTE OPERATION

Note: All remote control accessories must be purchased separately (see Accessories, page 19). Follow instructions included with the remote control.

NOTICE: You must light the pilot before using the hand-held remote control unit. See Lighting Instructions on page 12.

After lighting, let pilot flame burn for about one minute. Turn control knob to ON position. Adjust flame adjustment knob anywhere between HI and LO. Slide the selector switch to the REMOTE position (see Figure 18).

Note: The burner may light if hand-held remote was on when selector switch was last turned off. You can now turn the burner on and off with the hand-held remote control unit.

IMPORTANT: Do not leave the selector switch in the REMOTE or ON position when the pilot is not lit. This will drain the battery.

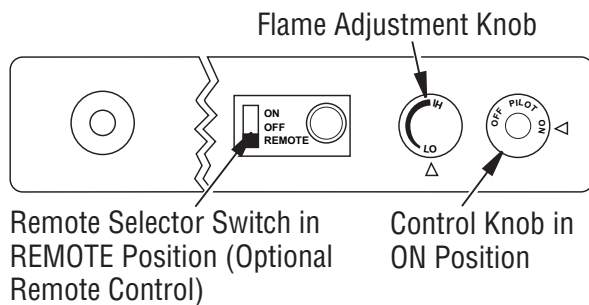

Figure 18 - Setting the Remote Selector Switch, Control Knob and Flame Adjustment Knob for Remote Operation

INSPECTING BURNERS

Check pilot flame pattern and burner flame patterns often.

PILOT FLAME PATTERN

Figure 19 shows a correct pilot flame pattern. Figure 20 shows an incorrect pilot flame pattern. The incorrect pilot flame is not heating the thermocouple. This will cause the thermocouple to cool. When the thermocouple cools, the appliance will shut down.

If pilot flame pattern is incorrect, as shown in Figure 20.

- turn appliance off (see To Turn Off Gas to Appliance
- see Troubleshooting, page 17

Note: The pilot flame on natural gas units will have a slight curve, but flame should be blue and have no yellow or orange color.

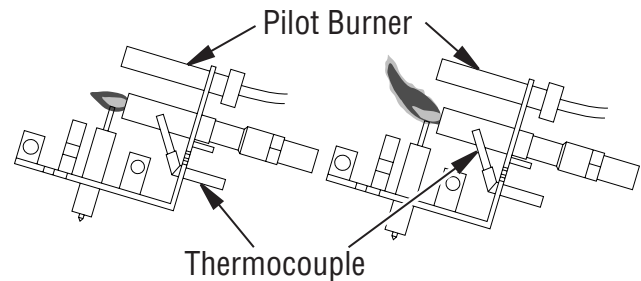

Figure 19 - Correct Pilot Flame Pattern (Propane/LP Shown) **Figure 20 - Incorrect Pilot Flame Pattern (Propane/LP Shown)**

BURNER PRIMARY AIR HOLES

Air is drawn into the burner through the holes in the fitting at the burner entrance. These holes may become blocked with dust or lint. Periodically inspect these holes for any blockage and clean if needed. Blocked air holes will create soot.

MAIN BURNER

Periodically inspect all burner flame holes with the appliance running. All slotted burner flame holes should be open with yellow flame present. All round burner flame holes should be open with a small blue flame present. Some burner flame holes may become blocked by debris or rust, with no flame present. If so, turn off appliance and let cool. Remove blockage. Blocked burner flame holes will create soot.

CLEANING AND MAINTENANCE

⚠ WARNING: Turn off appliance and let cool before cleaning.

⚠ CAUTION: You must keep control areas, burner and circulating air passageways of appliance clean. Inspect these areas of appliance before each use. Have appliance inspected yearly by a qualified service person. Appliance may need more frequent cleaning due to excessive lint from carpeting, pet hair, bedding material, etc.

⚠ WARNING: Failure to keep the primary air opening(s) of the burner(s) clean may result in sooting and property damage.

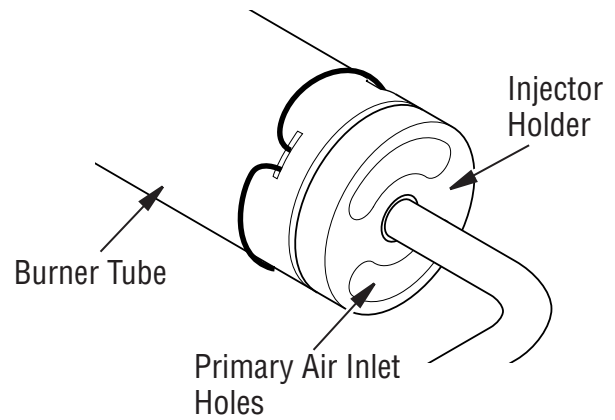

Figure 21 - Injector Holder On Outlet Burner Tube

BURNER INJECTOR HOLDER AND PILOT AIR INLET HOLE

The primary air inlet holes allow the proper amount of air to mix with the gas. This provides a clean burning flame. Keep these holes clear of dust, dirt, lint and pet hair. Clean these air inlet holes prior to each heating season. Blocked air holes will create soot. We recommend that you clean the unit every three months during operation and have appliance inspected yearly by a qualified service person.

We also recommend that you keep the burner tube and pilot assembly clean and free of dust and dirt. To clean these parts we recommend using compressed air no greater than 30 PSI. Your local computer store, hardware store or home center may carry compressed air in a can. If using compressed air in a can, please follow the directions on the can. If you don't follow directions on the can, you could damage the pilot assembly. Note: Removing the rear panel (Figure 5, page 8) and top grate(s) of your stove will make cleaning easier.

1. Shut off unit, including pilot. Allow unit to cool for at least thirty minutes.
2. Inspect burner, pilot and primary air inlet holes on injector holder for dust and dirt (see Figure 21).
3. Blow air through the ports/slots and holes in the burner.
4. Check injector holder located at end of burner tube again. Remove any large particles of dust, dirt, lint or pet hair with a soft cloth or vacuum cleaner nozzle.
5. Blow air into the primary air holes on the injector holder.
6. In case any large clumps of dust have now been pushed into the burner repeat steps 3 and 4.

Clean the pilot assembly also. A yellow tip on the pilot flame indicates dust and dirt in the pilot assembly. There is a small pilot air inlet hole about 2" from where the pilot flame comes out of the pilot assembly (see Figure 22). With the unit off, lightly blow air through the air inlet hole. You may blow through a drinking straw if compressed air is not available.

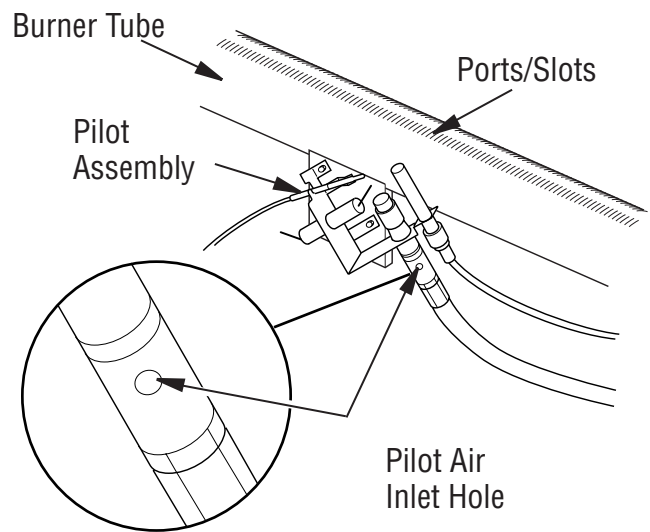

Figure 22 - Pilot Inlet Air Hole

TROUBLESHOOTING

⚠ WARNING: Turn off appliance and let cool before servicing. Only a qualified service person should service and repair appliance.

⚠ CAUTION: Never use a wire, needle or similar object to clean ODS/pilot. This can damage ODS/pilot unit.

Note: All troubleshooting items are listed in order of operation.

OBSERVED PROBLEM	POSSIBLE CAUSE	REMEDY
When Igniter button is pressed, there is no spark at ODS/pilot	<ol style="list-style-type: none"> 1. Igniter electrode not connected to Igniter cable 2. Igniter cable pinched or wet 3. Broken Igniter cable 4. Bad piezo Igniter 5. Igniter electrode broken 6. Igniter electrode positioned wrong 	<ol style="list-style-type: none"> 1. Reconnect Igniter cable 2. Free Igniter cable if pinched by any metal or tubing. Keep Igniter cable dry 3. Replace Igniter cable 4. Replace piezo Igniter 5. Replace pilot assembly 6. Replace pilot assembly
When Igniter button is pressed, there is spark at ODS/pilot but no ignition	<ol style="list-style-type: none"> 1. Gas supply turned off or equipment shutoff valve closed 2. Control knob not in PILOT position 3. Control knob not pressed in while in PILOT position 4. Air in gas lines when installed 5. ODS/pilot is clogged 6. Gas regulator setting is not correct 7. Depleted gas supply (propane/LP only) 	<ol style="list-style-type: none"> 1. Turn on gas supply or open equipment shutoff valve 2. Turn control knob to PILOT position 3. Press in control knob while in PILOT position 4. Continue holding down control knob. Repeat igniting operation until air is removed 5. Clean ODS/pilot (see Cleaning and Maintenance, page 14) or replace ODS/pilot assembly 6. Replace gas control 7. Contact local propane/LP gas company
ODS/pilot lights but flame goes out when control knob is released	<ol style="list-style-type: none"> 1. Control knob not fully pressed in 2. Control knob not pressed in long enough 3. Equipment shutoff valve not fully open 4. Pilot flame not touching thermocouple, which allows thermocouple to cool, causing pilot flame to go out. This problem could be caused by one or both of the following: <ol style="list-style-type: none"> A) Low gas pressure B) Dirty or partially clogged ODS/pilot 5. Thermocouple connection loose at control valve 6. Thermocouple damaged 7. Control valve damaged 	<ol style="list-style-type: none"> 1. Press in control knob fully 2. After ODS/pilot lights, keep control knob pressed in 30 seconds 3. Fully open equipment shutoff valve 4. <ol style="list-style-type: none"> A) Contact local propane/LP or natural gas company B) Clean ODS/pilot (see Cleaning and Maintenance, page 14) or replace ODS/pilot assembly 5. Hand tighten until snug, then tighten 1/4 turn more 6. Replace pilot assembly 7. Replace control valve

TROUBLESHOOTING *Continued*

OBSERVED PROBLEM	POSSIBLE CAUSE	REMEDY
Burner does not light after ODS/pilot is lit	<ol style="list-style-type: none"> 1. Burner orifice clogged 2. Inlet gas pressure is too low 3. Thermopile leads disconnected or improperly connected 4. Burners will not come on in remote position 	<ol style="list-style-type: none"> 1. Clean burner (see Cleaning and Maintenance, page 14) or replace burner orifice 2. Contact local propane/LP or natural gas company 3. Reconnect leads (see Wiring Diagram, page 18) 4. Replace battery in transmitter and hand-held remote
Delayed ignition burner	<ol style="list-style-type: none"> 1. Manifold pressure is too low 2. Burner orifice clogged 	<ol style="list-style-type: none"> 1. Contact local propane/LP or natural gas company 2. Clean burner (see Cleaning and Maintenance, page 14) or replace burner orifice
Burner backfiring during combustion	<ol style="list-style-type: none"> 1. Burner orifice is clogged or damaged 2. Damaged burner 3. Gas regulator defective 	<ol style="list-style-type: none"> 1. Clean burner (see Cleaning and Maintenance, page 14) or replace burner orifice 2. Replace damaged burner 3. Replace gas control
Slight smoke or odor during initial operation	<ol style="list-style-type: none"> 1. Not enough air 2. Gas regulator defective 3. Residues from manufacturing processes and logs curing 	<ol style="list-style-type: none"> 1. Check burner for dirt and debris. If found, clean burner (see Cleaning and Maintenance, page 14) 2. Replace gas control 3. Problem will stop after a few hours of operation
Moisture/condensation noticed on windows	<ol style="list-style-type: none"> 1. Not enough combustion/ventilation air 	<ol style="list-style-type: none"> 1. Refer to Air for Combustion and Ventilation requirements (page 5)
Appliance produces a whistling noise when burner is lit	<ol style="list-style-type: none"> 1. Turning control knob to HI position when burner is cold 2. Air in gas line 3. Air passageways on appliance blocked 4. Dirty or partially clogged burner orifice 	<ol style="list-style-type: none"> 1. Turn control knob to LO position and let warm up for a minute 2. Operate burner until air is removed from line. Have gas line checked by local propane/LP or natural gas company 3. Observe minimum installation clearances (see page 7) 4. Clean burner (see Cleaning and Maintenance, page 14) or replace burner orifice
Dark residue on logs or inside of stove	<ol style="list-style-type: none"> 1. Improper log placement 2. Drafts or other air currents affecting flame pattern 3. Air holes at burner inlet blocked 4. Burner flame holes blocked 	<ol style="list-style-type: none"> 1. Properly locate logs (see Installing Gas Log Into Stove, page 8) 2. Eliminate source of drafts around appliance 3. Clean out air holes at burner inlet. Periodically repeat as needed 4. Remove blockage or replace burner

TROUBLESHOOTING *Continued*

- ⚠ WARNING: If you smell gas**
- Shut off gas supply.
 - Do not try to light any appliance.
 - Do not touch any electrical switch; do not use any phone in your building.
 - Leave the building immediately.
 - Immediately call your gas supplier from a neighbor's phone. Follow the gas supplier's instructions.
 - If you cannot reach your gas supplier, call the fire department.

IMPORTANT: Operating appliance where impurities in air exist may create odors. Cleaning supplies, paint, paint remover, cigarette smoke, cements and glues, new carpet or textiles, etc., create fumes. These fumes may mix with combustion air and create odors. These odors will disappear over time.

OBSERVED PROBLEM	POSSIBLE CAUSE	REMEDY
White powder residue forming within burner box or on adjacent walls or furniture	1. When heated, vapors from furniture polish, wax, carpet cleaners, etc. may turn into white powder residue	1. Turn appliance off when using furniture polish, wax, carpet cleaners or similar products
Remote does not function	1. Battery is not installed. Battery power is low	1. Replace batteries in receiver and handheld remote control
Appliance produces a clicking/ticking noise just after burner is lit or shut off	1. Metal expanding while heating or contracting while cooling	1. This is normal with most appliances. If noise is excessive, contact qualified service person
Appliance produces unwanted odors	1. Appliance burning vapors from paint, hair spray, glues, cleaners, chemicals, new carpet, etc. (See IMPORTANT statement above) 2. Gas leak. See Warning statement at top of page	1. Open window and ventilate room. Stop using odor causing products while appliance is running 2. Locate and correct all leaks (see Checking Gas Connections , page 10)
Appliance shuts off in use (ODS operates)	1. Not enough fresh air is available 2. Low line pressure 3. ODS/pilot is partially clogged	1. Open window and/or door for ventilation 2. Contact local propane/LP or natural gas company 3. Clean ODS/pilot (see Cleaning and Maintenance , page 14)
Gas odor even when control knob is in OFF position	1. Gas leak. See Warning statement at top of page 2. Control valve defective	1. Locate and correct all leaks (see Checking Gas Connections , page 10) 2. Replace control valve
Gas odor during combustion	1. Foreign matter between control valve and burner 2. Gas leak. See Warning statement at top of page	1. Take apart gas tubing and remove foreign matter 2. Locate and correct all leaks (see Checking Gas Connections , page 10)

WIRING DIAGRAM

Note: For proper operation of optional accessories, the wires from the switch to the control must be connected exactly as shown.

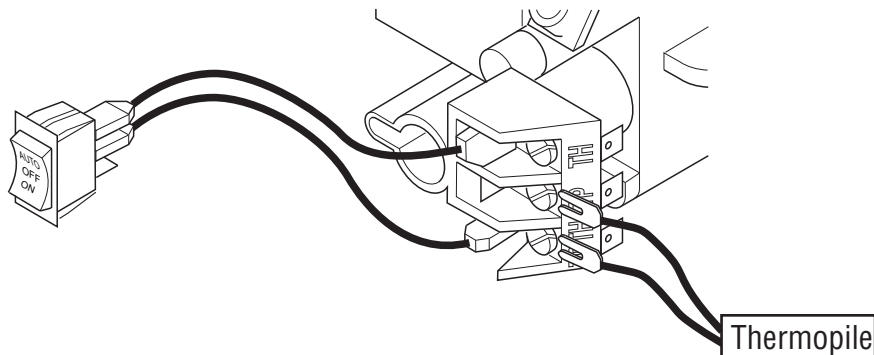

SPECIFICATIONS

NCBurnerZMP

- Rating: 21,000/31,000 Btu/hr (Variable)
- Gas Type: Propane/LP
- Ignition: Piezo
- Pressure Manifold: 8" W.C.
- Inlet Gas Pressure (in. of water):
Maximum - 14" W.C., Minimum - 11" W.C.
- Shipping Weight: 28 lbs.

NCBurnerZMN

- Rating: 24,000/35,000 Btu/hr (Variable)
- Gas Type: Natural
- Ignition: Piezo
- Pressure Manifold: 3.5" WC
- Inlet Gas Pressure (in. of water):
Maximum - 10.5" W.C., Minimum - 5" W.C.
- Shipping Weight: 28 lbs.

* For purposes of input adjustment

SERVICE HINTS

When Gas Pressure Is Too Low

- pilot will not stay lit
- burner will have delayed ignition
- appliance will not produce specified heat
- for propane/LP unit, propane/LP gas supply may be low

You may feel your gas pressure is too low. If so, contact your local gas supplier.

TECHNICAL SERVICE

You may have further questions about installation, operation, or troubleshooting. Please contact your IHP dealer for any questions or concerns. When contacting your dealer please have your model and serial numbers of your appliance ready. You can also visit our web site at Comfortflame.US.com.

REPLACEMENT PARTS

See Pages 20 to 21 for a complete replacement parts list. Use only parts supplied from the manufacturer.

Normally, all parts should be ordered through your IHP distributor or dealer. Parts will be shipped at prevailing prices at time of order.

When ordering repair parts, always give the following information:

1. The model number of the appliance.
2. The serial number of the appliance.
3. The part number.
4. The description of the part.
5. The quantity required.
6. The installation date of the appliance.



If you encounter any problems or have any questions concerning the installation or application of this appliance, please contact your dealer.

IHP

1508 Elm Hill Pike, Suite 108
Nashville, TN 37210
Visit us at Comfortflame.US.com

ACCESSORIES

Purchase these accessories from your local dealer. If they can not supply these accessories contact IHP at Comfortflame.US.com for information.

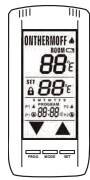
CAT NO.	MODEL	DESCRIPTION	
RECEIVER AND THERMOSTAT REMOTE CONTROL KIT			
For all Remote-Ready Models. Allows the gas log appliance to be operated in a manually or thermostatically controlled mode. You can turn the gas log appliance on and off without ever leaving the comfort of your easy chair.			
F1078	TRC	Thermostatic On/Off Remote Control Kit	
RECEIVER AND ON/OFF REMOTE CONTROL KIT			
For all Remote-Ready Models. Allows the gas log appliance to be turned on and off by using a hand-held remote control.			
F1077	MRC	Standard On/Off Remote Control Kit	
RECEIVER AND ON/OFF TOUCH SCREEN REMOTE CONTROL KIT			
For all Remote-Ready Models. Allows the burner system to be operated in a manually or thermostatically controlled mode. Remote is programmable for your convenience and has a large bright LCD Touch Screen for easy use.			
F1079	TSRC	Receiver and Touch Screen Remote Control Kit	
WALL-MOUNT THERMOSTAT SWITCH			(Not Shown)
For remote-ready models. The desired comfort setting can be selected on the wall thermostat and the log appliance will automatically cycle from pilot to the heat setting selected.			
F2040	GWMT1	Thermostat Wall Mount kit	
WALL-MOUNT ON/OFF SWITCH			(Not Shown)
For remote-ready models. Allows the gas log appliance to be turned on and off with a wall switch.			
F0245	GWMS2	Switch Wall Mount Kit	

PARTS

MODELS NCBURNERZMN AND NCBURNERZMP

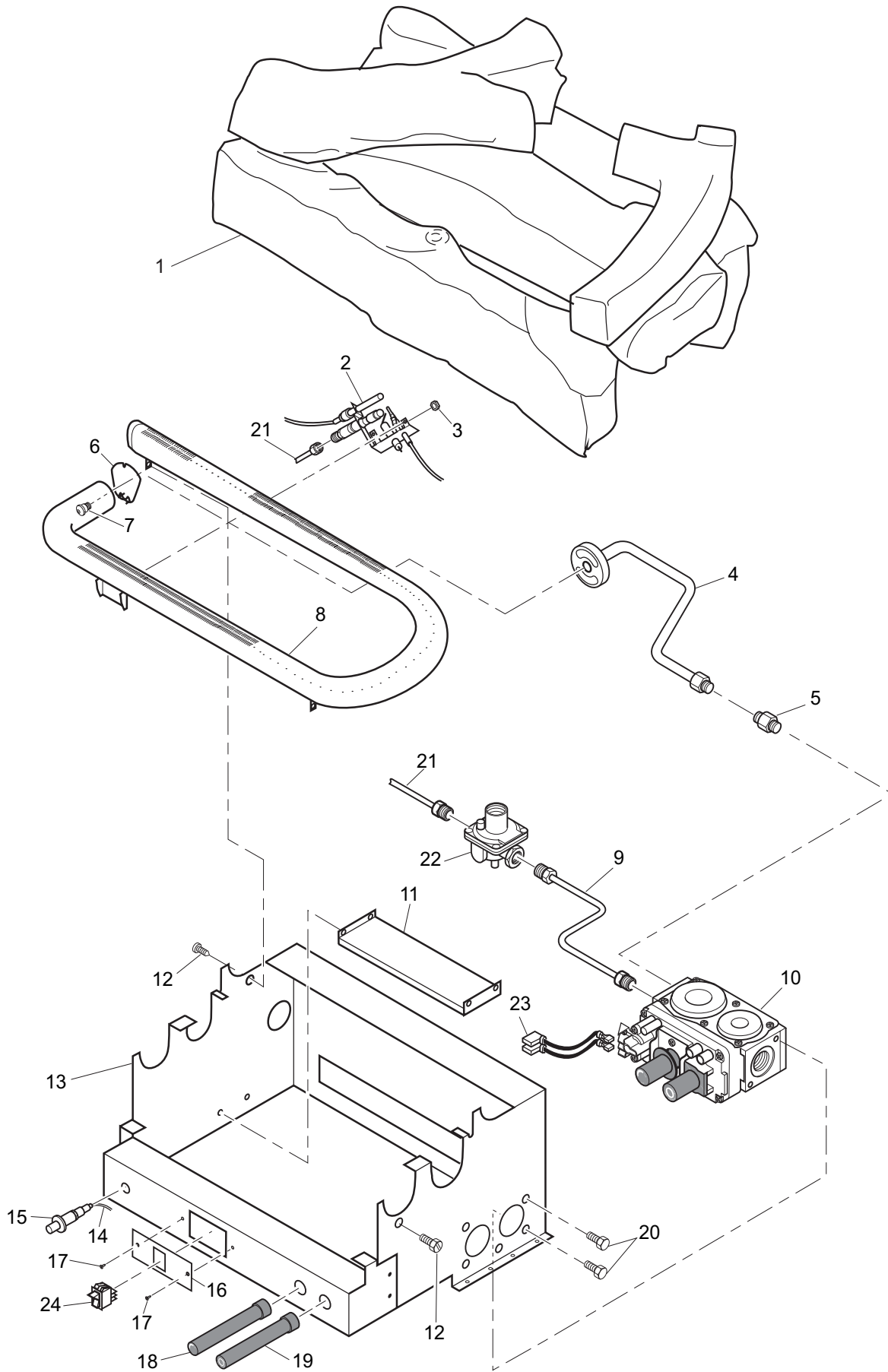

PARTS

This list contains replaceable parts used in your appliance. When ordering parts, follow the instructions listed under [Replacement Parts](#) on page 18 of this manual.

⚠ WARNING: Contact an IHP dealer to obtain any of these parts. Never use substitute materials not approved by IHP. Use of non-approved parts can result in poor performance and safety hazards.

KEY NO.	CATALOG NO.	DESCRIPTION	NCBurnerZMP		NCBurnerZMN	QTY.
			F2512	F2511	F2511	
1	J3850	LOG SET, YF-STOVE	•	•		1
2	J3830	PILOT, ODS LP (8414)	•			1
	J3831	PILOT, ODS NG (8218)		•		1
3	J3558	NUT, ODS (M5 X 0.8)				2
4	J3874	BURNER OUTLET TUBE	•	•		1
5	J3562	CONNECTOR, MALE 3/8NPTF 3/8TUBE	•	•		1
6	J4514	SPRING, BURNER RETAINER	•	•		1
7	J3607	INJECTOR, .0670 1,70MM	•			1
	J3612	INJECTOR, (.1070)2.72MM		•		1
8	J3784	BURNER	•	•		1
9	J3638	TUBE, PILOT	•			1
	J3640	TUBE, PILOT		•		1
10	J3837	VALVE, GAS LP (0.820.642)	•			1
	J3836	VALVE, GAS NG (0.820.643)		•		1
11	J3808	LOWER BRACKET	•	•		1
12	J1958	SCREW, HWH AB 8-18 X .38	•	•		7
13	**	PAINTED BASE ASSEMBLY	•	•		1
14	J3569	CABLE, IGNITER	•	•		1
15	J3746	KIT, IGNITER SERVICE	•	•		1
16	J3821	PLATE, SWITCH	•	•		1
17	J3574	SCREW, PPH AB 10-16 X .38	•	•		2
18	J3843	KNOB, LONG EXTENSION (HI-LO)	•	•		1
19	J3842	KNOB, LONG EXTENSION (PILOT)	•	•		1
20	J1961	SCREW, HX SLT WSR 10-32X3/8	•	•		4
21	J3660	TUBING, PILOT	•	•		1
22	J3654	REGULATOR, PILOT	•	•		1
23	J3794	WIRE, HARNESS	•	•		1
24	J3656	SWITCH, ON/AUTO/OFF	•	•		1
PARTS AVAILABLE — NOT SHOWN						
	J3658	PLATE, WARNING	•	•		1
	J3846	PLATE, LIGHTING INSTRUCTIONS	•	•		1
	J3690	KIT, HARDWARE	•	•		1
	J4640	STOVE DROPPED PAN (BLACK ONLY)	•	•		1
	J4641	STOVE BACK PANEL (BLACK ONLY)	•	•		1
	J4642	ROD, CAST IRON STOVE	•	•		1
	J3804	ASM, SCREEN	•	•		1

**Not a field replaceable part.

Innovative Hearth Products

Comfort Flame® Brand Gas Fireplace, Stove and Insert

20 Year Limited Warranty

THE WARRANTY

Innovative Hearth Products ("IHP") 20 Year Limited Warranty warrants your Comfort Flame® Brand gas fireplace or insert ("Product") to be free from defects in materials and workmanship at the time of manufacture. The Product body and firebox carry the 20 Year Limited Warranty. Ceramic glass carries the 20 Year Limited Warranty against thermal breakage only. After installation, if covered components manufactured by IHP are found to be defective in materials or workmanship during the 20 Year Limited Warranty period and while the Product remains at the site of the original installation, IHP will, at its option, repair or replace the covered components. If repair or replacement is not commercially practical, IHP will, at its option, refund the purchase price or wholesale price of the IHP product, whichever is applicable. IHP will also pay IHP prevailing labor rates, as determined in its sole discretion, incurred in repairing or replacing such components for up to five years. THERE ARE EXCLUSIONS AND LIMITATIONS to this 20 Year Limited Warranty as described herein.

COVERAGE COMMENCEMENT DATE

Warranty coverage begins on the date of purchase. In the case of new home construction, warranty coverage begins on the date of first occupancy of the dwelling or six months after the sale of the Product by an independent IHP dealer/distributor, whichever occurs earlier. The warranty shall commence no later than 24 months following the date of product shipment from IHP, regardless of the installation or occupancy date.

EXCLUSIONS AND LIMITATIONS

This 20 Year Limited Warranty applies only if the Product is installed in the United States or Canada and only if operated and maintained in accordance with the printed instructions accompanying the Product and in compliance with all applicable installation and building codes and good trade practices.

This warranty is non-transferable and extends to the original owner only. The Product must be purchased through a listed supplier of IHP and proof of purchase must be provided. The Product body and firebox carry the 20 Year Limited Warranty from the date of installation. Vent components, trim components and paint are excluded from this 20 Year Limited Warranty. The following do not carry the 20 Year Limited Warranty but are warranted as follows:

- Burner** – Repair or replacement for one year from the date of installation
- Gas components** – Repair or replacement for one year from the date of installation
- Gaskets** – Repair or replacement for one year from the date of installation
- Gold & nickel plating** – Replacement for two years from date of installation. Excludes tarnishing
- Logs** – Replacement for one year from the date of installation against thermal breakage only
- Optional blowers & remote controls** – Repair or replacement for one year from the date of installation
- Optional glass doors** – Repair or replacement for 90 days from the date of installation
- Tempered glass** – Replacement for one year from the date of installation
- Labor coverage** – Prevailing IHP labor rates apply for the warranty period of the component

Parts not otherwise listed carry a 90 day warranty from the date of installation.

Whenever practicable, IHP will provide replacement parts, if available, for a period of 10 years from the last date of manufacture of the Product.

IHP will not be responsible for: (a) damages caused by normal wear and tear, accident, riot, fire, flood or acts of God; (b) damages caused by abuse, negligence, misuse, or unauthorized alteration or repair of the Product affecting its stability or performance (The Product must be subjected to normal use. The Product is designed to burn either natural or propane gas only. Burning conventional fuels such as wood, coal or any other solid fuel will cause damage to the Product, will produce excessive temperatures and could result in a fire hazard.); (c) damages caused by failing to provide proper maintenance and service in accordance with the instructions provided with the Product; (d) damages, repairs or inefficiency resulting from faulty installation or application of the Product.

IHP is not responsible for inadequate fireplace system draft caused by air conditioning and heating systems, mechanical ventilation systems, or general construction conditions which may generate negative pressure in the room in which the appliance is installed. Additionally IHP assumes no responsibility for drafting conditions caused by venting configurations, adjoining trees or buildings, adverse wind conditions or unusual environmental factors and conditions that affect the operation of the unit.

This 20 Year Limited Warranty covers only parts and labor as provided herein. In no case shall IHP be responsible for materials, components or construction, which are not manufactured or supplied by IHP or for the labor necessary to install, repair or remove such materials, components or construction. Additional utility bills incurred due to any malfunction or defect in equipment are not covered by this warranty. All replacement or repair components will be shipped F.O.B. from the nearest stocking IHP factory.

LIMITATION ON LIABILITY

It is expressly agreed and understood that IHP's sole obligation and the purchaser's exclusive remedy under this warranty, under any other warranty, expressed or implied, or in contract, tort or otherwise, shall be limited to replacement, repair, or refund, as specified herein.

In no event shall IHP be liable for any incidental or consequential damages caused by defects in the Product, whether such damage occurs or is discovered before or after repair or replacement, and whether such damage is caused by IHP's negligence. IHP has not made and does not make any representation or warranty of fitness for a particular use or purpose, and there is no implied condition of fitness for a particular use or purpose.

IHP makes no expressed warranties except as stated in this 20 Year Limited Warranty. The duration of any implied warranty is limited to the duration of this expressed warranty.

No one is authorized to change this 20 Year Limited Warranty or to create for IHP any other obligation or liability in connection with the Product. Some states and provinces do not allow the exclusion or limitation of incidental or consequential damages, so the above limitations or exclusions may not apply to you. The provisions of this 20 Year Limited Warranty are in addition to and not a modification of or subtraction from any statutory warranties and other rights and remedies provided by law.

INVESTIGATION OF CLAIMS AGAINST WARRANTY

IHP reserves the right to investigate any and all claims against this 20 Year Limited Warranty and to decide, in its sole discretion, upon the method of settlement.

To receive the benefits and advantages described in this 20 Year Limited Warranty, the appliance must be installed and repaired by a licensed contractor approved by IHP.

Contact IHP at the address provided herein to obtain a listing of approved dealers/distributors. **IHP shall in no event be responsible for any warranty work done by a contractor that is not approved without first obtaining IHP's prior written consent.**

HOW TO REGISTER A CLAIM AGAINST WARRANTY

In order for any claim under this warranty to be valid, you must contact the IHP dealer/distributor from which you purchased the product. If you cannot locate the dealer/distributor, then you must notify IHP in writing. IHP must be notified of the claimed defect in writing within 90 days of the date of failure. Notices should be directed to the IHP Warranty Department at 1508 Elm Hill Pike, Suite 108; Nashville, TN 37210 or visit our website at WWW.COMFORTFLAME.US.COM.

Record the following important information about your appliance:

Appliance model number	
Appliance serial number	
Date appliance was Installed	
Type of gas appliance uses	
Dealer name	



P900577-00

Innovative Hearth Products reserves the right to make changes at any time, without notice, in design, materials, specifications, prices and also to discontinue colors, styles and products. Consult your local distributor for appliance code information.

Printed in U.S.A. © 2016 Innovative Hearth Products LLC

P/N 900577-00 Rev. NC 02/2016



1508 Elm Hill Pike, Suite 108 • Nashville, TN 37210